

# 21 DIY Robotics & Science Project Guide

An E-Book for science fairs, Raman awards, inspire awards etc.

## General instructions

- Every project has an associated QR code. Some projects may contain videos, some projects may contain code, some projects may contain downloadable templates. You can scan the associated QR Code to access all these.
- All the projects mentioned here are made using Havi's robotics kit. With Havi Robotics Kits, one can make 100+ robotics & STEAM Creations, making it a perfect choice for schools.
- For any queries, questions related to any project, or to get the components to make the project, call/WhatsApp on 7041681929 or email on [toys@havi.co](mailto:toys@havi.co)

## Disclaimer

All rights reserved to the copyright holder. No part of this book can be reproduced in any form without written permission from the copyright holder.

Copyright © Havi Technologies Pvt Ltd  
[www.havi.co](http://www.havi.co)

# Table of Contents

---

- Chapter 1**    **How to make a radar system using ultrasonic sensor - 3**  
<https://www.havi.co/blogs/diy-radar-system>
  
- Chapter 2**    **Smart dustbin project - step by step guide - 10**  
<https://www.havi.co/blogs/smart-dustbin-project>
  
- Chapter 3**    **How to make a DIY Table fan project - 15**  
<https://www.havi.co/blogs/diy-table-fan>
  
- Chapter 4**    **How to make a pushup counter using python and Havi Controller - 20**  
<https://www.havi.co/blogs/diy-pushup-counter>
  
- Chapter 5**    **DIY Automatic Sanitizer Dispenser - 24**  
<https://www.havi.co/blogs/diy-automatic-sanitizer-dispenser>
  
- Chapter 6**    **Accident prevention system for hairpin bend zone in hills - 28**  
<https://www.havi.co/blogs/accident-prevention-system>
  
- Chapter 7**    **How to make a line follower robot - 33**  
<https://www.havi.co/blogs/make-line-follower-robot>
  
- Chapter 8**    **How to make an obstacle avoiding robot - 38**  
<https://www.havi.co/blogs/obstacle-avoiding-robot>
  
- Chapter 9**    **DIY Train collision avoidance system using Havi Elements - 41**  
<https://www.havi.co/blogs/train-collision-avoidance-system>
  
- Chapter 10**    **How to make an edge avoiding robot - 43**  
<https://www.havi.co/blogs/make-edge-avoiding-robot>
  
- Chapter 11**    **Make a moving solar system working model using Havi Elements - 47**  
<https://www.havi.co/blogs/moving-solar-system-model>
  
- Chapter 12**    **DIY Conveyor Belt with sensor using Havi Elements - 53**  
<https://www.havi.co/blogs/diy-conveyor-belt>
  
- Chapter 13**    **How to make automatic hand dryer at home - 58**  
<https://www.havi.co/blogs/how-to-make-hand-dryer>
  
- Chapter 14**    **Reverse Car Parking Sensor Project using Havi Elements - 62**  
<https://www.havi.co/blogs/reverse-car-parking-sensor-project>
  
- Chapter 15**    **How to make automatic street light project - 66**  
<https://www.havi.co/blogs/how-to-make-automatic-street-light>

**Chapter 16** **Make a smart street light project using IR sensor - 71**

<https://www.havi.co/blogs/smart-street-light-with-ir-sensor>

**Chapter 17** **Automatic headlight dimmer/dipper project using Havi Elements - 75**

<https://www.havi.co/blogs/automatic-headlight-dipper-project>

**Chapter 18** **DIY Automatic water dispenser model using Cardboard & Havi Elements - 78**

<https://www.havi.co/blogs/diy-automatic-water-dispenser>

**Chapter 19** **How to make a river cleaning robot project using propeller & Havi Elements - 87**

<https://www.havi.co/blogs/river-cleaning-robot-project>

**Chapter 20** **How to make vacuum cleaner at Home - 93**

<https://www.havi.co/blogs/how-to-make-vacuum-cleaner>

**Chapter 21** **Reflex action working model - Step by step guide - 100**

<https://www.havi.co/blogs/reflex-action-model>

## Chapter 1

# How to make a radar system using ultrasonic sensor

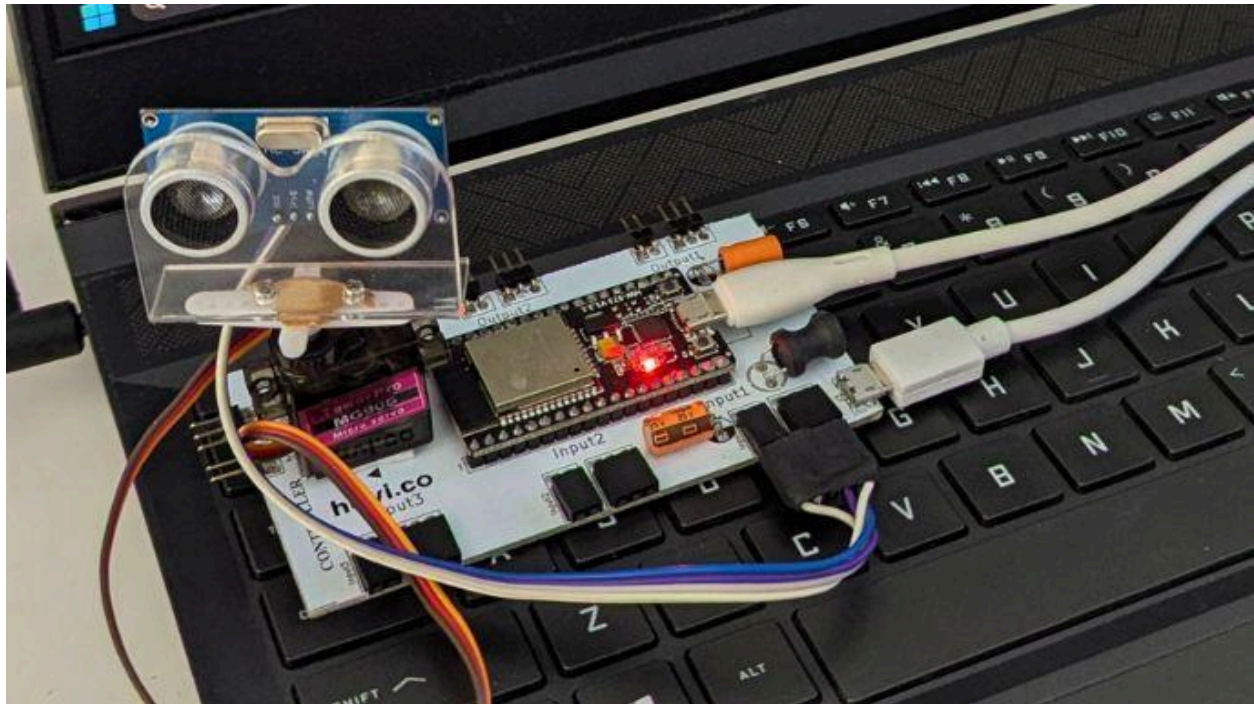

Have you ever wondered how submarines, warships, or even self-driving cars know what's around them without using eyes? A submarine can "see" underwater, an airplane can sense the nearest airport, and an autonomous car can detect obstacles in its path. But here's the catch — they don't see the way we do. Instead, they use sound waves to sense their surroundings.

This technology is called SONAR — Sound Navigation and Ranging. SONAR works by sending out ultrasonic sound waves (very high-frequency sounds we can't hear) and listening for their echoes when they bounce back from objects. By measuring the time taken for the echo to return, the system can figure out how far away an object is, and even map its position.

There are two types of SONAR systems:

1. Passive SONAR — it only listens for sound sources. Because it's quiet and stealthy, it's often used in military applications.
2. Active SONAR — it actively sends out sound pulses and measures the returning echoes to calculate distances.

Similar to SONAR, there is another technology which is called RADAR - Radio Detection and Ranging. This technology uses radio waves instead of sound waves to detect the object. The primary medium where RADAR is used is air/space while SONAR is used underwater.

In this blog, we are going to make a radar system, but using the ultrasonic sensor, Havi controller (an esp32 based microcontroller, more powerful than arduino) and the servo motor. Together, it let us scan the environment, just like submarines and smart machines, and build our very own sound-based "eyes.". You can make this python project to showcase the military applications & safety applications in your science fairs. Get all the components from Havi advanced robotics kit add-on. Or you can contact us to get these project-specific components.

## Things you need to make Radar system

Elements	Accessories	Craft material	For programming
Havi Controller Ultrasonic sensor - 2 Servo motor - 1	Power bank with USB cable Data cable Servo motor mount	Card board Cutter/Scissor	Computer or laptop Software: Thonny, Python IDE(3.13.7+) or Havi MicoPy

### How to make

We are going to make 4 variations of radar system

1. 180 sonar mapped(locally hosted)
2. 360 sonar mapped(locally hosted)
3. 180 sonar mapped(web hosted)
4. 360 sonar mapped(web hosted)

First, let's make the circuit.

**Step 1** — Connect the ultrasonic sensor to input 1 of the Havi controller.

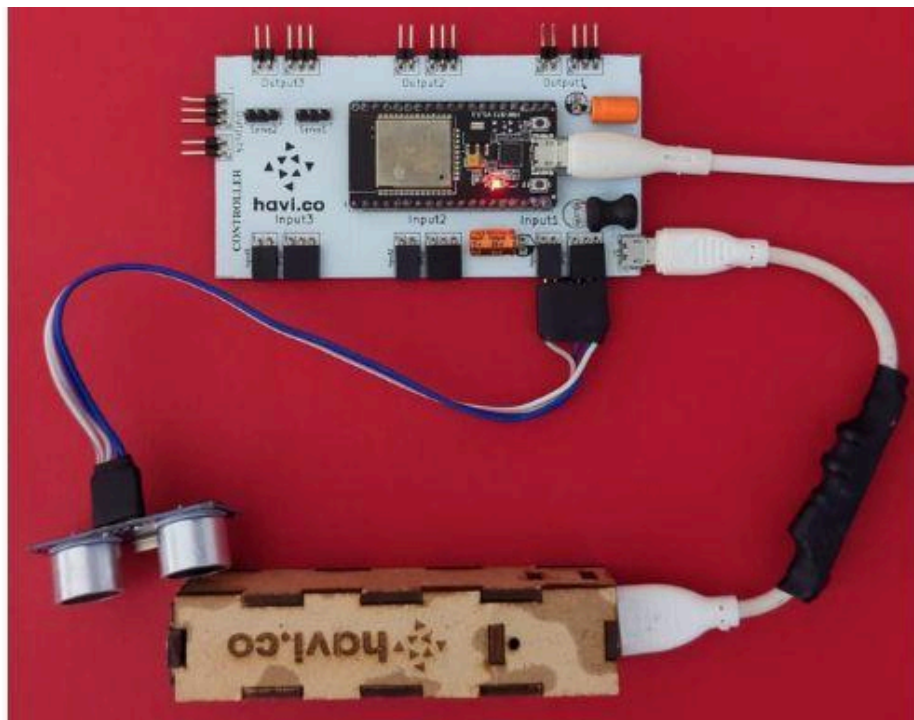

**Step 2** — Connect the servo motor to servo 1 port of the Havi controller.

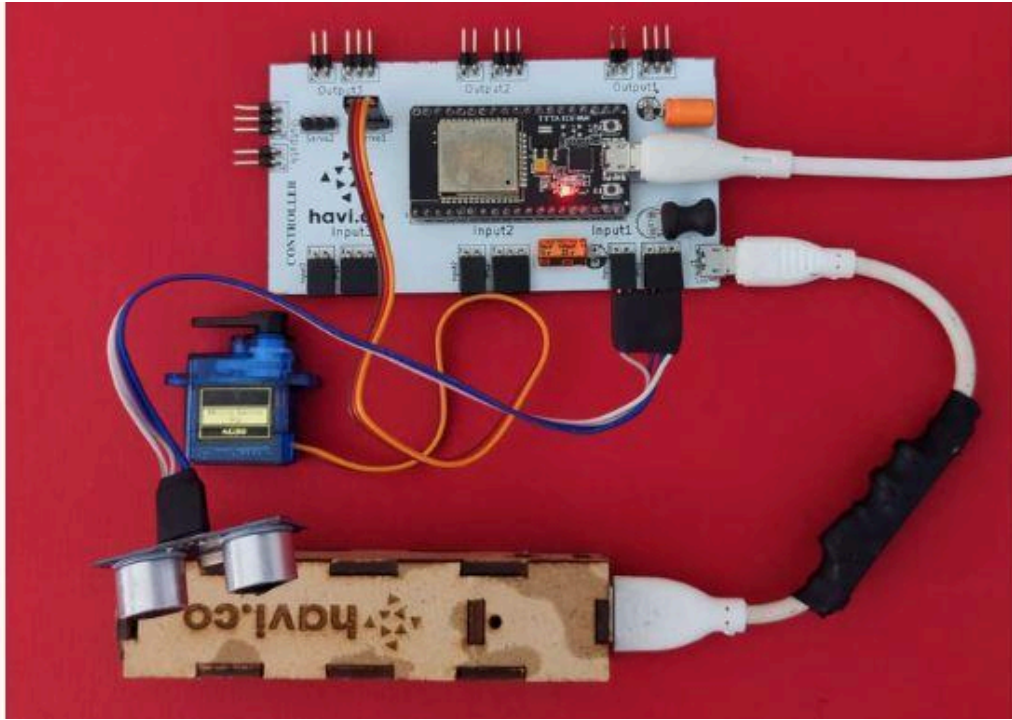

**Step 3** — Connect the controller to the laptop/desktop using data cable & connect the power bank with controller using USB cable. Open the Thonny & check for the correct COM Port on the bottom right, and stop any ongoing execution.

**Project variation 1: 180 Degrees mapped radar(Locally hosted)**

**Step 4** — Attach the ultrasonic sensor mount onto the servo and place the sensor in it.

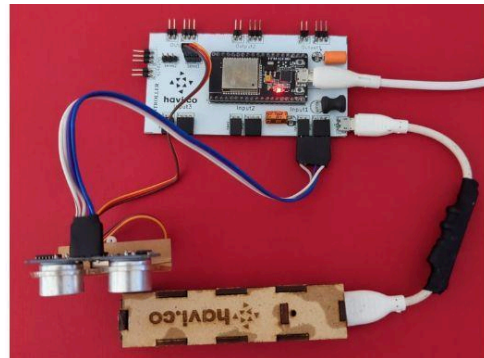
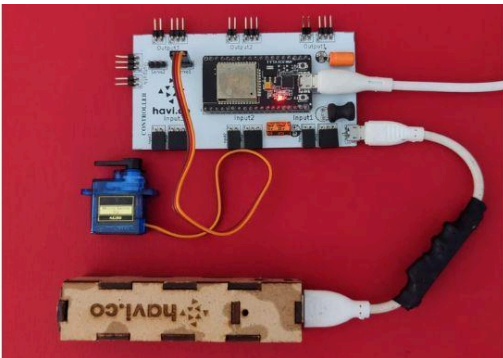

**Step 5** — Download the python program files by clicking on the following button. You will receive code files in a zip folder. Extract that. The files included are in .txt and .py format. In case, if you find any formatting issue in .py file, you can use the code from .txt file.

**Step 6** — Create a folder "Radar" in your laptop/computer & save the file '180\_SONAR\_Local\_Visual.py' in that folder. Note the address of the file. Check the COM port & change the COM Port to that of the controller if not the same already.

```

180_SONAR_Visual.py
1 import serial
2 import matplotlib.pyplot as plt
3 import numpy as np
4 import time
5
6 # --- Serial setup ---
7 ser = serial.Serial('COM4', 115200, timeout=1) # <-- Change COM port if needed
8 time.sleep(2) # wait for ESP32 to reset
9
10 # --- Matplotlib setup ---
11 plt.ion() # interactive mode
12 fig, ax = plt.subplots(subplot_kw={'projection': 'polar'})
13 ax.set_theta_zero_location("N")
14 ax.set_theta_direction(-1)
15 ax.set_ylim(0, 100) # max distance in cm

```

MicroPython (ESP32) • COM3

Port no. should be similar. If they are not, change it. For eg. in this program, you need to change the port no. to COM3

**Step 7** — Paste the file "RunSONARLocal\_180.txt" from downloaded folder to "Radar" folder. Open the file "RunSONARLocal\_180.txt". The code will be as below: "`@echo off cd /d "Your file address" python "180_SONAR_Local_Visual.py" pause`" Here, 'Your file address' refers to the file location of '180\_SONAR\_Local\_Visual.py' file. So edit it accordingly. Save the text file as 'RunSONAR.bat' and keep 'All Files' type while saving in the 'Radar' folder.

**Step 8** — Now, in Thonny open the code named '180 SONAR\_Loc.py' and run the code, and close Thonny.

**Step 9** — Open the folder and double click the 'RunSONAR.bat' file, you will see a new window will open with a 2D SONAR map..

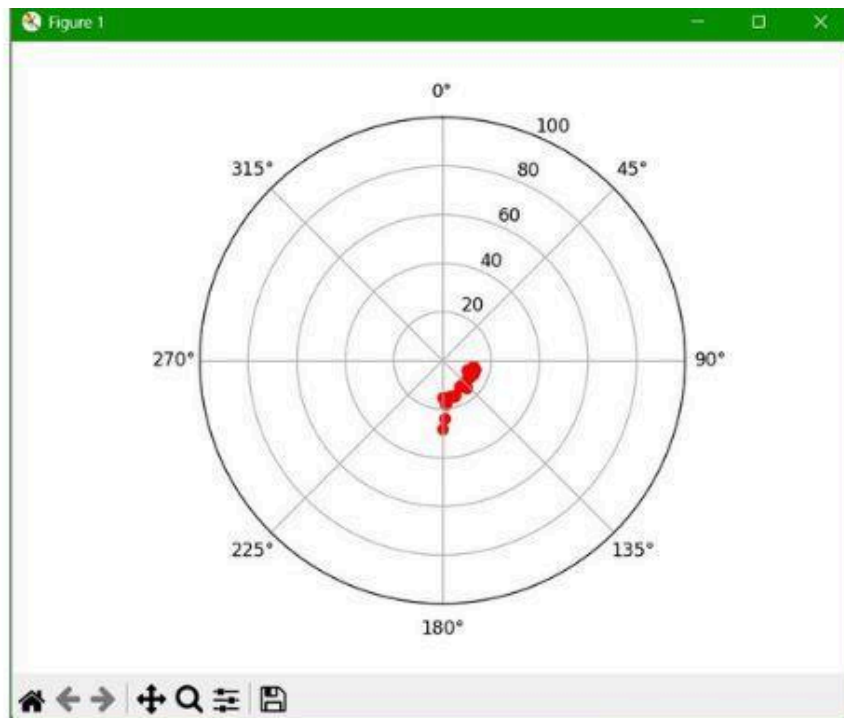

### Project variation 2: 360 Degrees mapped radar(Locally hosted)

Follow the first three steps as defined before

**Step 4** — Connect one more ultrasonic sensor to the input 2 of the Havi controller. Use cardboard to fix both ultrasonic sensor & attach servo motor with cardboard. Now, repeat step 6 to 9 from previous version. Use the code file '360\_SONAR\_Local\_Visual.py' instead of '180\_SONAR\_Local\_Visual.py'. Use 'RunSONARLocal\_360.txt' instead of 'RunSONARLocal\_180'. And use the sonar location map '360 SONAR\_Loc.py' file instead of '180 SONAR\_Loc.py'. And then when you open the 'RunSONAR.bat' file, you will see a new window will open with a 2D SONAR map.

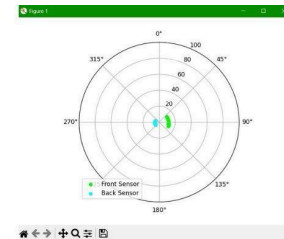
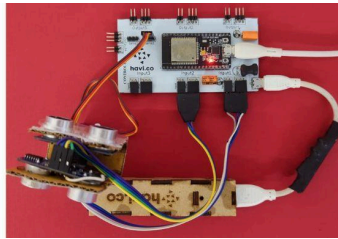
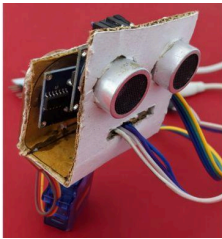

### Project variation 3: 180 Degree SONAR map - Web hosted

Follow the first three steps as defined before.

**Step 4** — Use the code file '180 SONAR\_Web.py' & save it to the 'Radar' folder.

**Step 5** — Enter your wifi name and password in the code (Case Sensitive).

```

180 SONAR_Web_1.py
1  import network
2  import time
3  import _thread
4  import collections
5  import socket
6  from havi import ports
7
8  # ===== WiFi =====
9  SSID = "WiFi network name (Case sensitive)"
10 PASSWORD = "WiFi password "
11
12 wifi = network.WLAN(network.STA_IF)
13 wifi.active(True)
14 wifi.disconnect()
15 wifi.connect(SSID, PASSWORD)
16
17 print("Connecting to WiFi...")
18 for i in range(20):

```

**Step 6** — Now in Thonny, open the code named '180 SONAR\_Web.py' and run the code, and check if the Wifi is connected or not in the shell. You can verify the wifi connection as below: Once successfully connected to the wifi, the server address will show up in the shell, copy that server address and paste it in the browser's address bar (Ensure the device opening the browser is connected to the same wifi as the Havi Controller).

**Step 7** — Now an active 2D SONAR Map will be displayed on the browser.

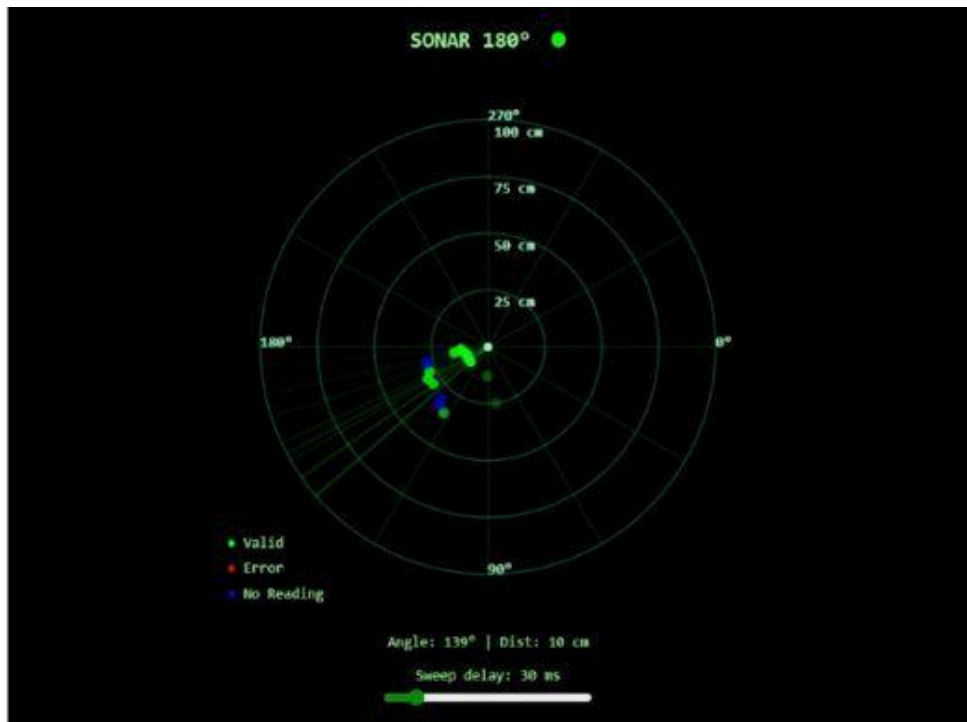

#### Project variation 4: 360 Degrees SONAR map - Web hosted

Follow the first three steps as defined before.

**Step 4** — Connect one more ultrasonic sensor to the input 2 of the Havi controller.

**Step 5** — Use the code file '360 SONAR\_Web.py' & save it to the 'Radar' folder.

Follow the steps 6 & 7 from the previous version. Instead of using the file '180 SONAR\_Web.py', use the file '360 SONAR\_Web.py'. The map will be generated as below in the browser.

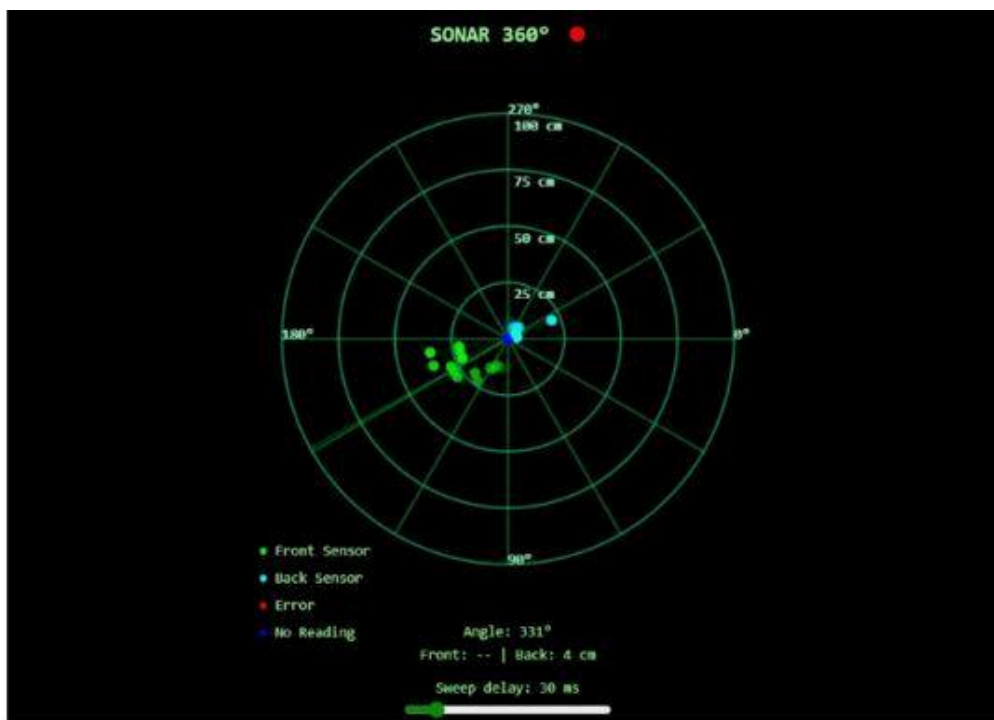

#### Shoot the object game using ultrasonic radar project

Look how Havi heroes have created one more variation of ultrasonic radar project. You can use your prediction to shoot the object identified in the radar system. Watch the following video:  
So this way, you can make all four variations of the SONAR system using Havi's advanced robotics kit.

## Chapter 2

# Smart dustbin project - step by step guide



Have you ever noticed how people hesitate to open the dustbin lid because it's dirty and sticky? And how does the foot pedal dustbin work only for a few days and then the pedal stops functioning?

This problem is common at home, in schools, playgrounds, and public places where many people use the same bin. Since no one likes touching dirty lids, waste often ends up being thrown near the dustbin instead of inside it. This leads to an unhygienic environment and unnecessary mess.

A smart dustbin solves this problem using technology. Here in this blog we have explained the technology and the step by step making process with photos and videos to make a smart dustbin project yourself at home or school. You also get the downloadable python code.

What is a smart dustbin?

A smart dustbin (automatic dustbin) opens its lid automatically when someone comes near it. It uses an ultrasonic sensor to detect movement and a servo motor to open and close the lid. An IR sensor placed inside the bin checks whether the dustbin is full, and a buzzer alerts about the door movement.

This touchless dustbin project is clean, hygienic, and easy to use. It encourages proper waste disposal and helps maintain cleaner surroundings.

Why build a Smart Dustbin?

- Hands-free and hygienic waste disposal
- Best science fair project for students
- Ideal IoT / robotics project for kids
- Demonstrates real-life use of sensors and automation

You can build this automatic smart dustbin project using Havi Robotics kits and present it in school exhibitions.

### Things you need

Elements	Accessories	Craft material	For programming
Havi Controller IR Element pair with 3-pin cable Buzzer Element Ultrasonic sensor Servo motor	Power bank - 2 Data cable USB cable Servo motor mount Small step on pedal dustbin	Cardboard Foam board Cutter/scissor Sticky tape Glue gun	Computer or laptop Havi MicoPy

All of these components can be found in Havi Elements - DIY Robotics Starter Kit + Havi Advanced Robotics Kit Add-on. Or you can request the required components by contacting us.

### How to make

**Step 1** — Carefully remove the lid of the dustbin. Ask an adult to help you remove the screws safely.

**Step 2** — Make a new lid using cardboard according to the size of the dustbin opening. Cut foam board pieces based on the dustbin dimensions to fix the cardboard lid with the dustbin.

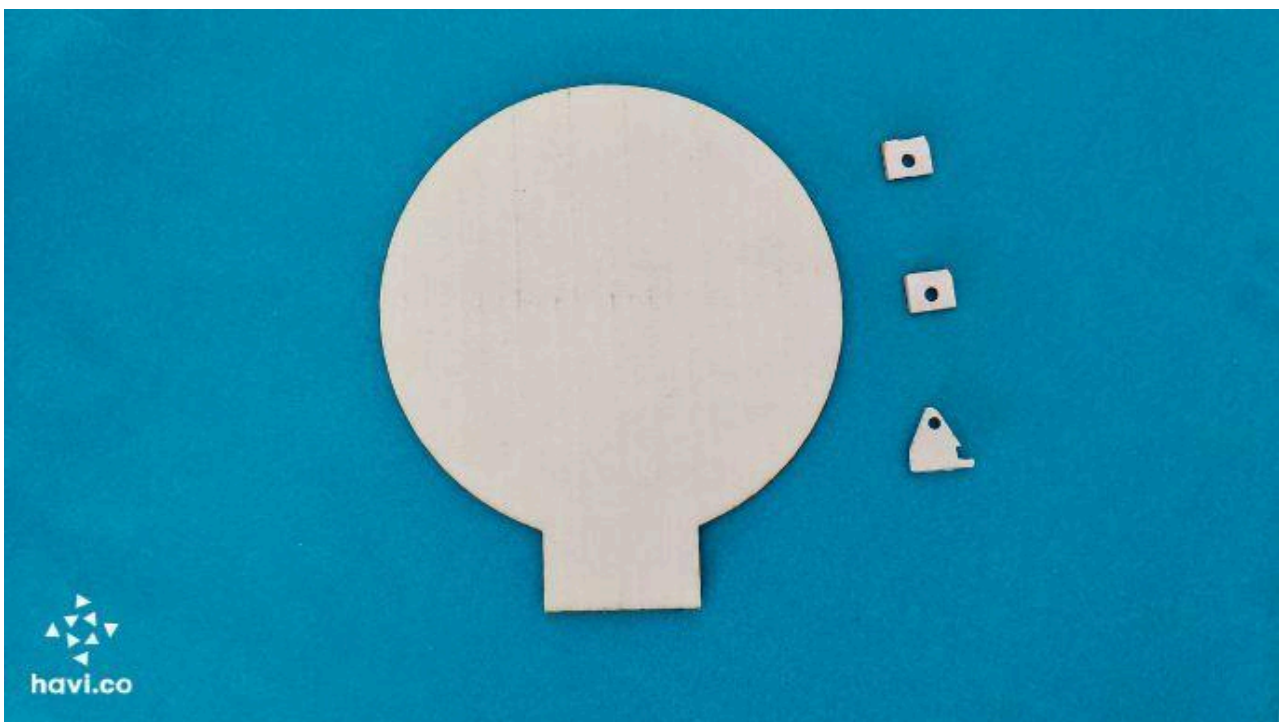

**Step 3** — Stick the foam board pieces to the cardboard lid using glue. Make sure the pieces are firmly fixed.

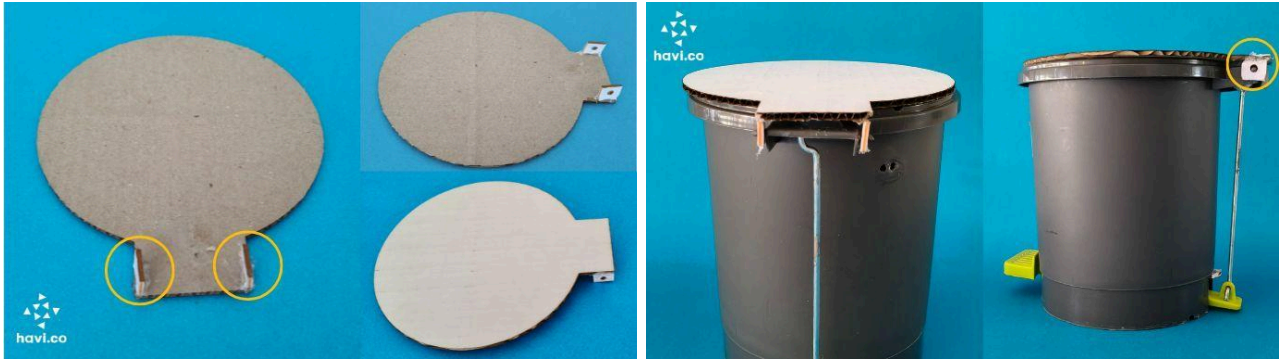

**Step 4** — Place the prepared cardboard lid on top of the dustbin. Stick a small cardboard piece at the center of the lid to fix it properly. Check that the lid is stable and does not move.



**Step 5** — Turn the dustbin upside down. Make a servo holder using cardboard of suitable height and stick it parallel to the bottom base of the dustbin. Fix the servo motor onto the servo holder as shown in the reference image.

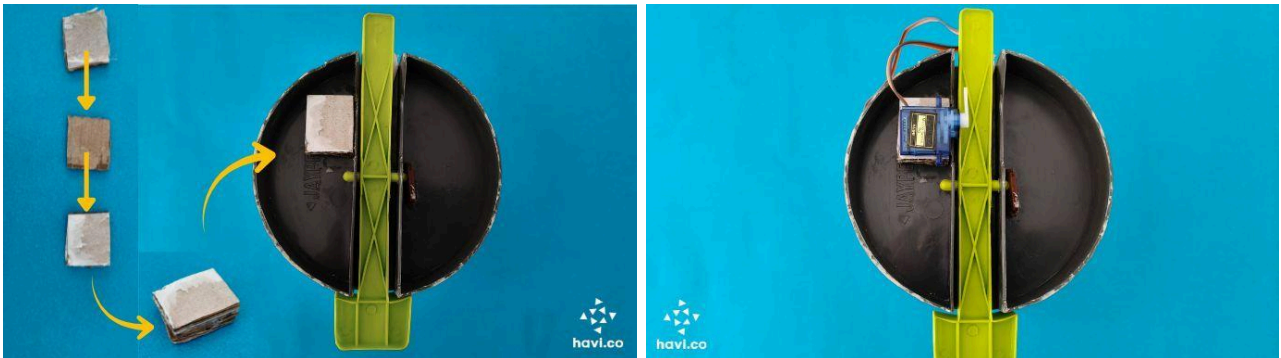

**Step 6** — Prepare the circuit connections as follows: • Connect the buzzer to output 3 of the Havi Controller • Connect the IR sensor to input 2 of the Havi Controller • Connect the ultrasonic sensor to input 1 of the Havi Controller • Connect the servo motor to servo port 2 of the Havi Controller

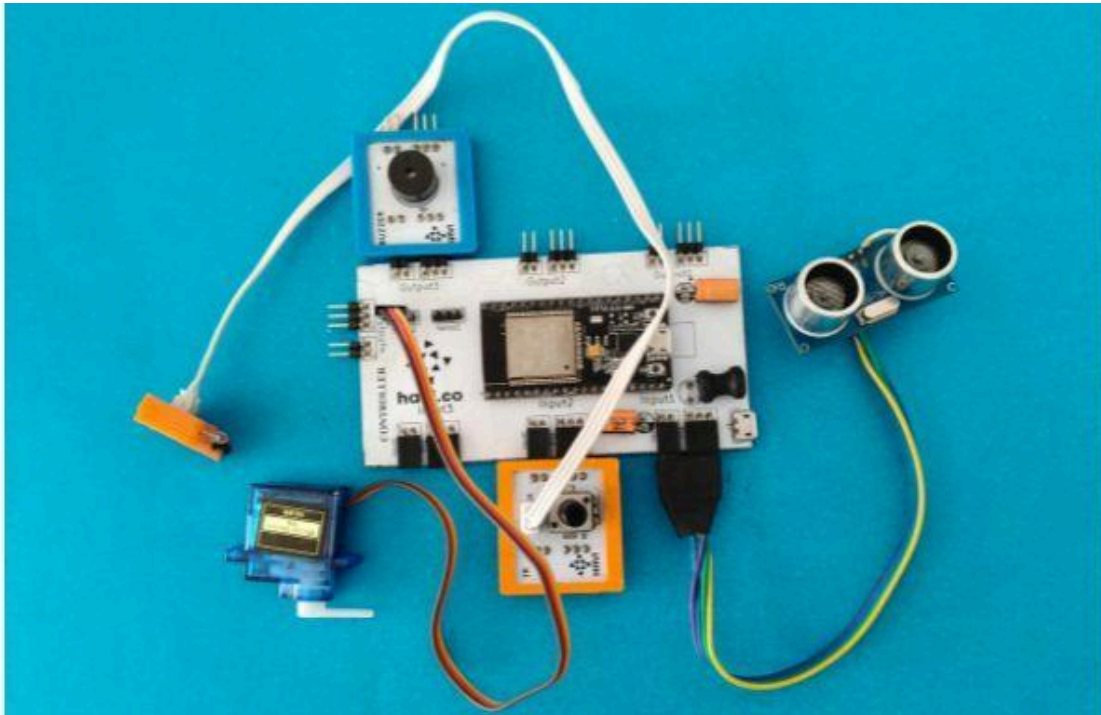

**Step 7** — Connect the Havi Controller to your computer using the correct COM port. Download the smart dustbin project code by clicking on the following button. Open Havi Code upload the provided code to main.py. Test the servo motor movement. If the servo rotates in the wrong direction, change the direction in the code and reupload main.py.

**Step 8** — Place the IR sensor LED inside the dustbin to detect whether the bin is full. Fix the ultrasonic sensor in front of the dustbin to detect a person approaching, as shown in the image. The smart dustbin is ready.





## How does it work?

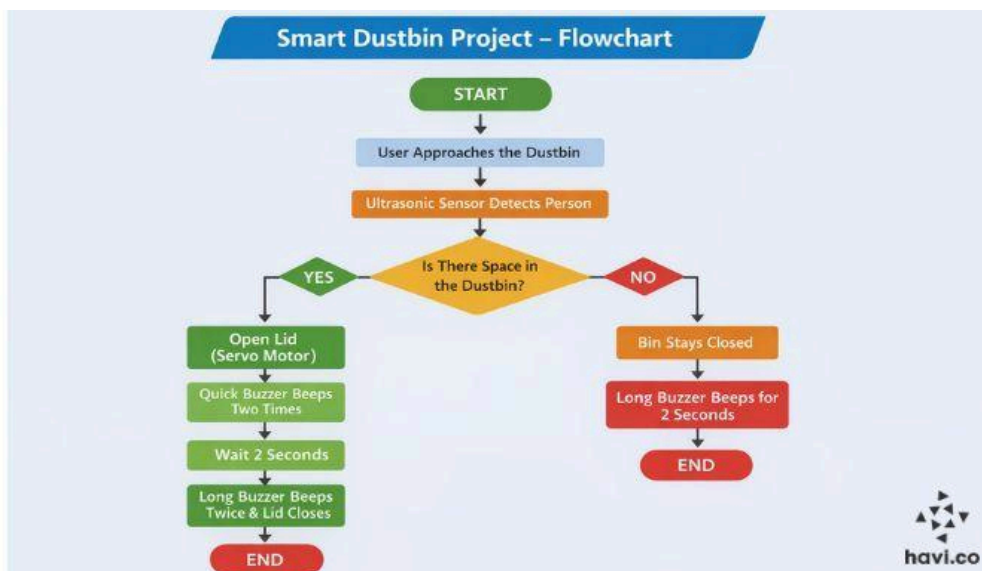

We have used two sensors in the smart dustbin project. The ultrasonic sensor is used to detect a person or trash at a certain distance. When someone brings trash near the ultrasonic sensor or stands in front of the dustbin, the sensor sends a signal to the servo motor. Servo motor rotates and pushes up the lid through the excel. Hence the lid opens automatically. You can put in the waste, and the lid closes automatically after 5 seconds. Why 5 seconds? Because we have mentioned the same in program. You can change that if required. The IR sensor is used to detect if there is space for more trash inside the dustbin. When the bin is full and someone comes nearby, the IR sensor informs the same to ultrasonic sensor. In this case, the dustbin does not open, and the buzzer alerts the user about same.

Two questions and one challenge to you.

Question 1: When will the servo start opening the lid again once the bin is full?

Question 2: How a human can know if the dustbin is full without trying to open it?

Hint: you have a blue colored element in your robotics starter kit which can be helpful here. And a challenge: can you do this modification yourself? Do it and send us across! – This way, you can make an automatic dustbin project and solve a real life problem.

Chapter 3

# How to make a DIY Table fan project

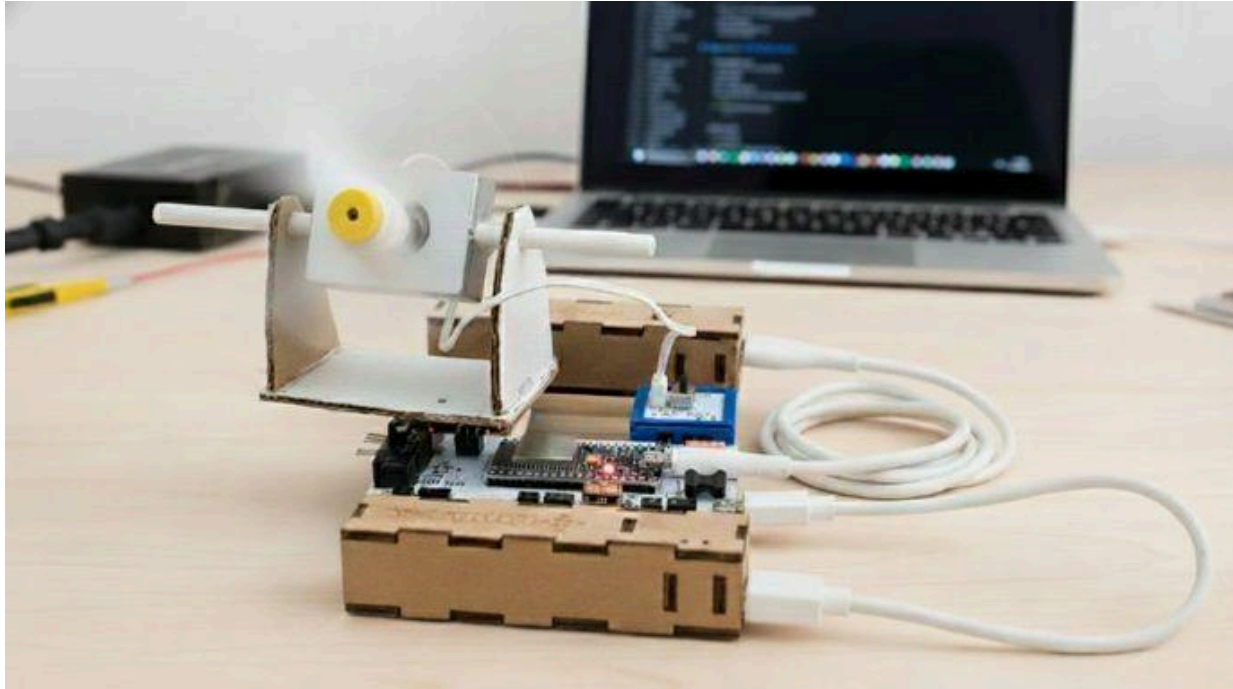

On a warm afternoon, a small fan sits on a table, quietly doing its job. As it spins and turns from side to side, it cools different corners of the room — sometimes facing you, sometimes drifting away, but always keeping the air moving. The gentle hum and steady breeze make the space feel calmer, fresher, and more relaxing.

This little fan makes daily life more comfortable: it keeps the room from feeling stuffy, helps you focus while studying, relax while playing, and rest peacefully after a long day. Instead of hot air getting trapped in one spot, the fan circulates it and spreads coolness around the room.

In this blog post, we are going to make a DIY table fan. You can use this table fan working model on your study desk to get the fresh air & also represent this table fan project in science fairs.

Let's make it. Find the components for making table fan project from Havi's robotics kits. Or contact us to get the separate elements to make a diy table fan project.

### Things you need

Elements	Accessories	Craft material	For programming
Havi Controller Motor Element	Gearless motor Servo motor Power bank - 2 USB Cable Data Cable	Cardboard Glue gun Paper straw Scale Pencil Cutter/scissor Double-sided tape Card paper	Computer or laptop Havi MicoPy

## How to make

**Step 1 table fan stand from craft material** — Let's first make the table fan stand from the pieces of cardboard & paper straws. Cut the cardboard and straws. And follow the steps as given in the following images. Use hot glue to stick the parts.

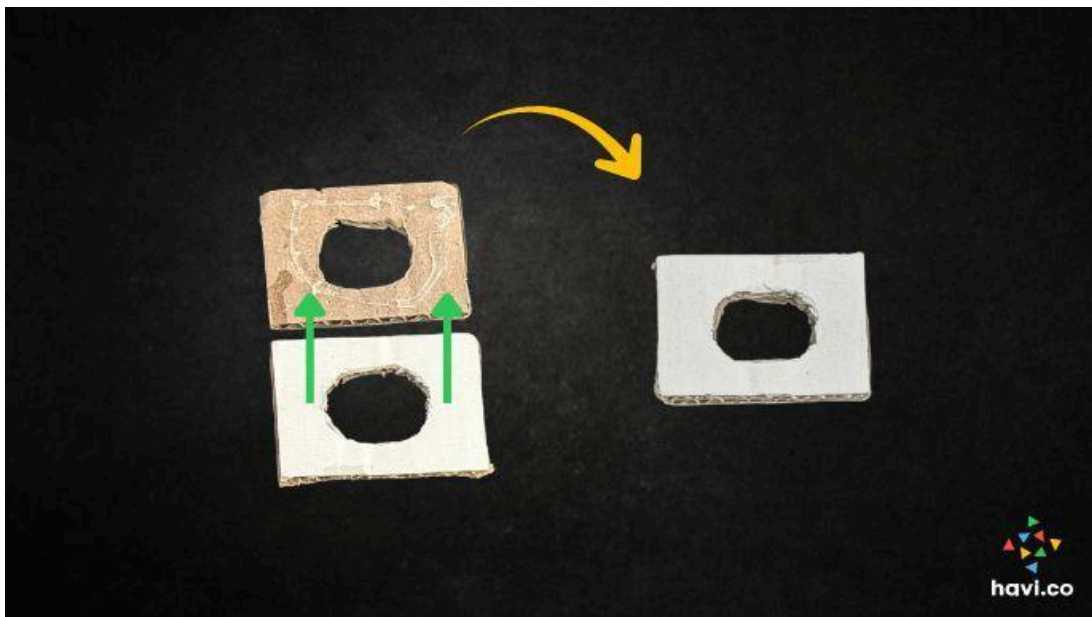
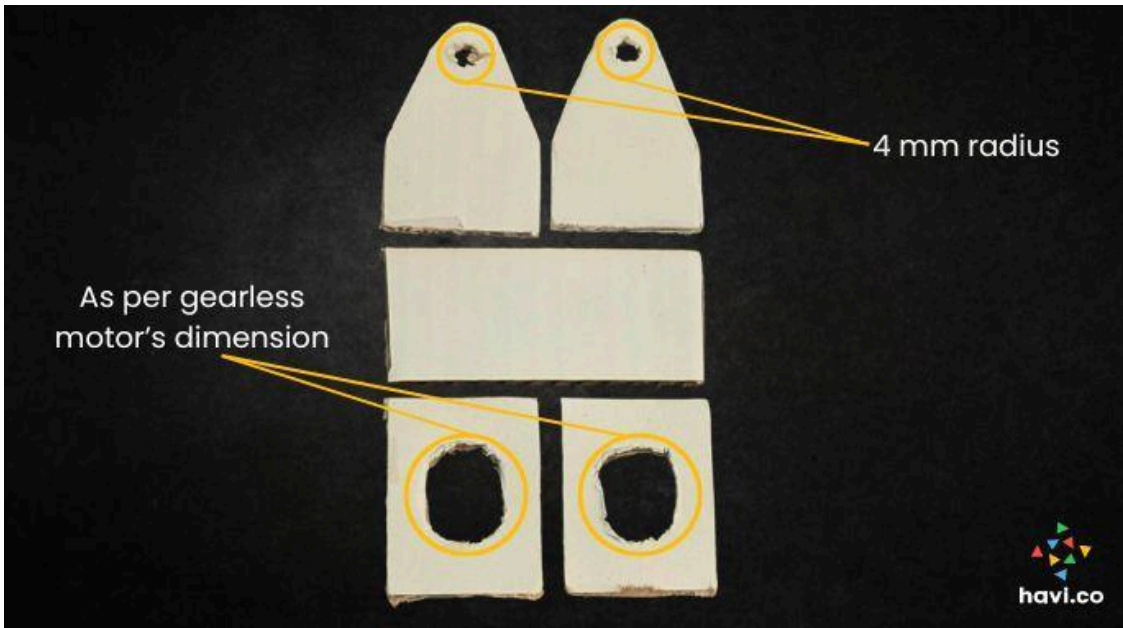

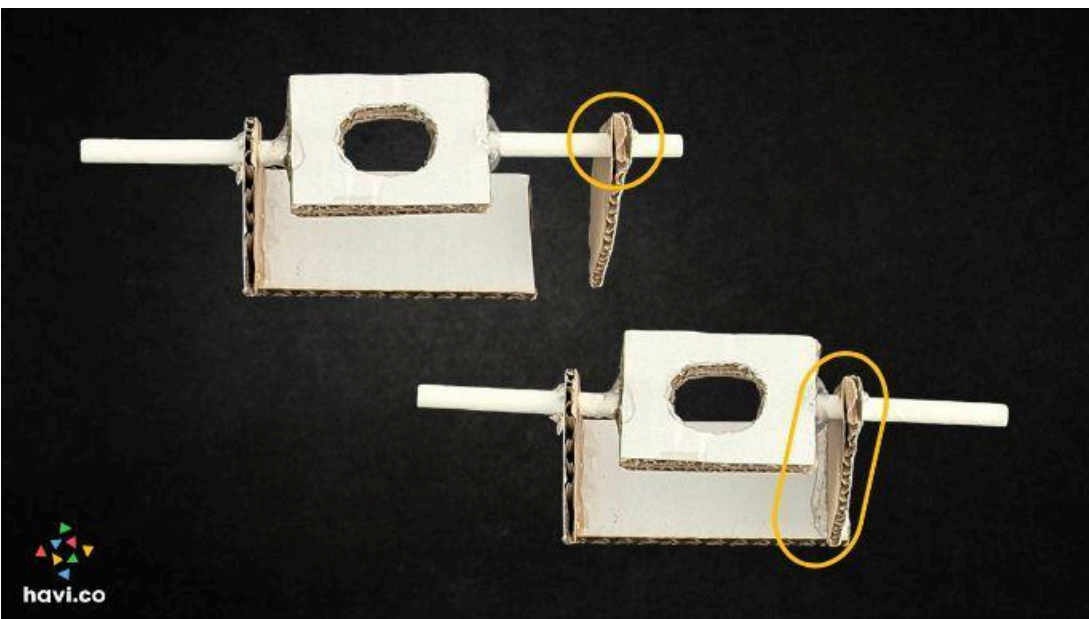
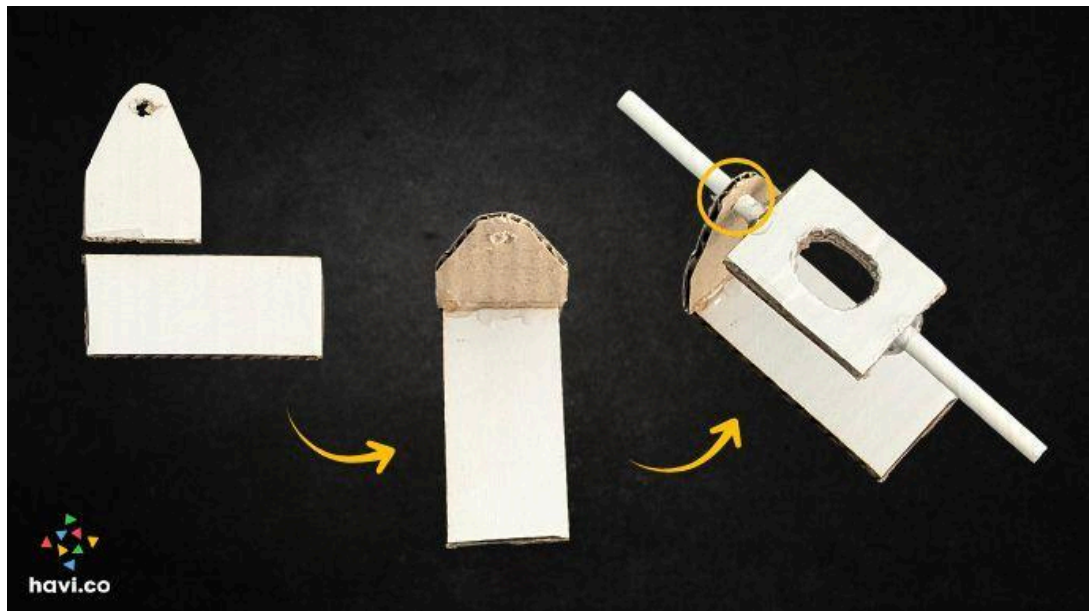
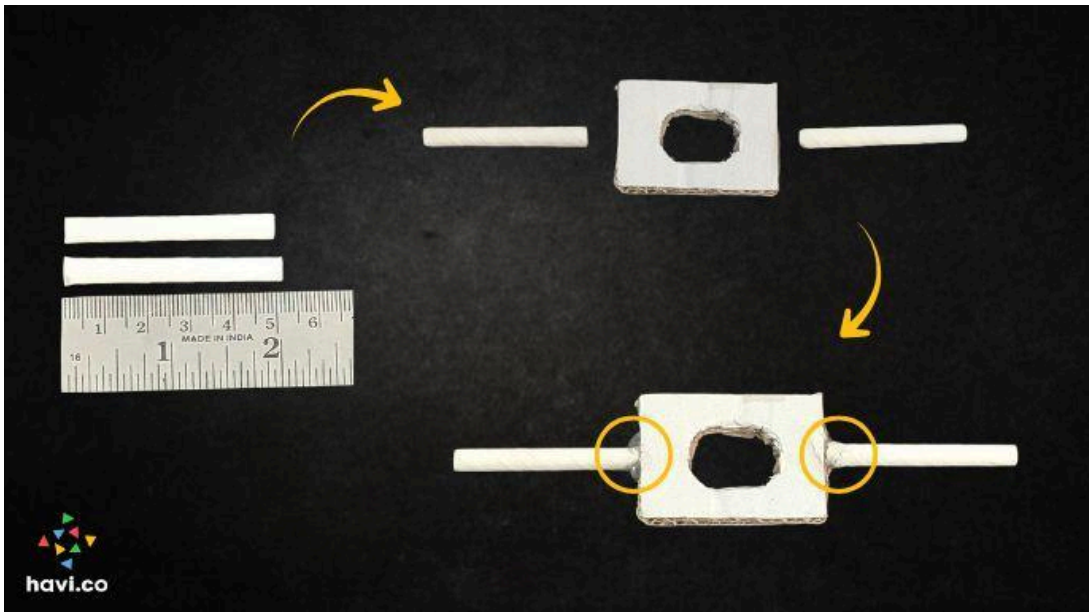

**Step 2** — Pass the gearless motor from the stand.

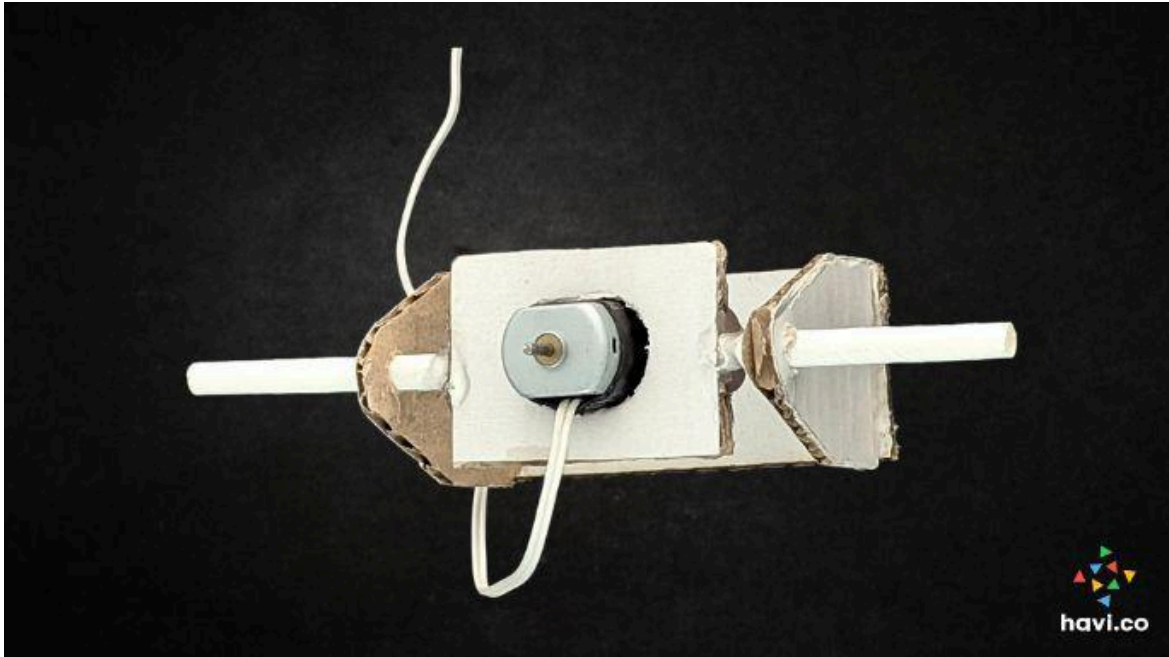

**Step 3** — Cut the paper-fan from a piece of chart/craft paper and bend a little from the sides. Stick a piece of double-sided tape at the center of the fan - both sides. Pass it through the shaft of the gearless motor. Stick the servo motor at the bottom of the table fan stand.

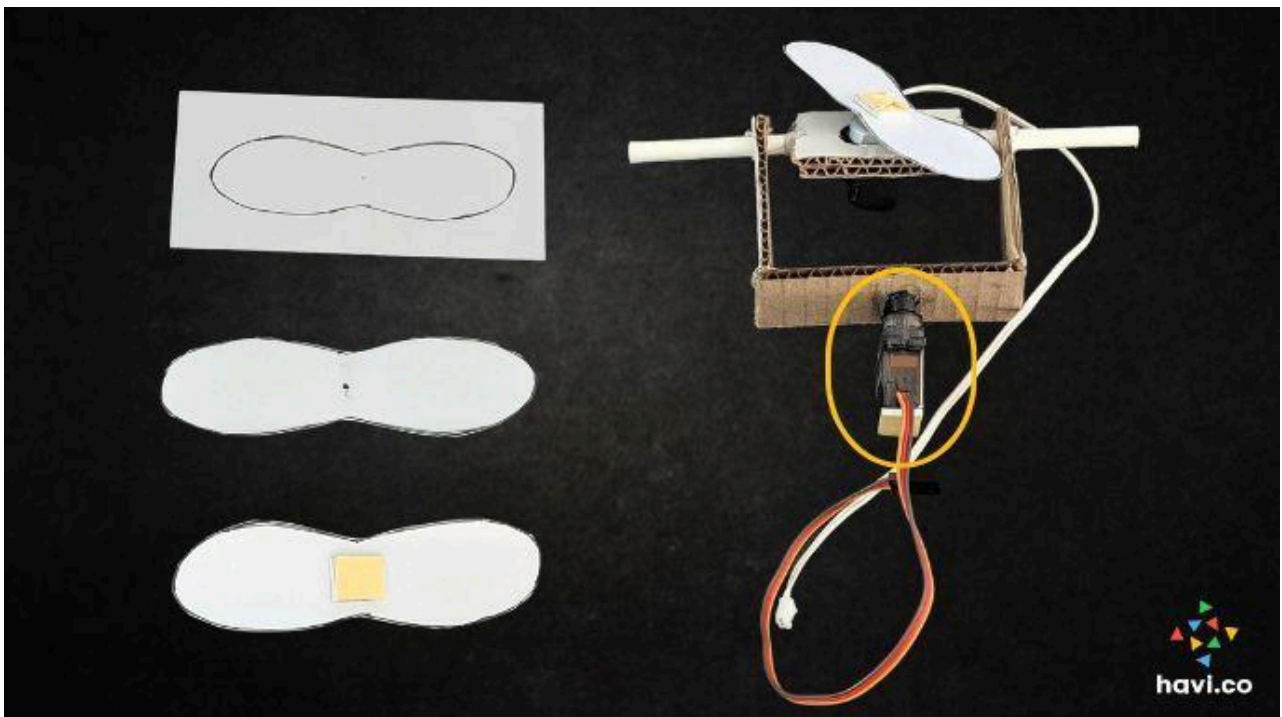

**Step 4** — Snap Motor Element with the output1 port and servo motor with the servo 1 port. Connect the gearless motor with the motor element. Connect one power bank using a USB cable.

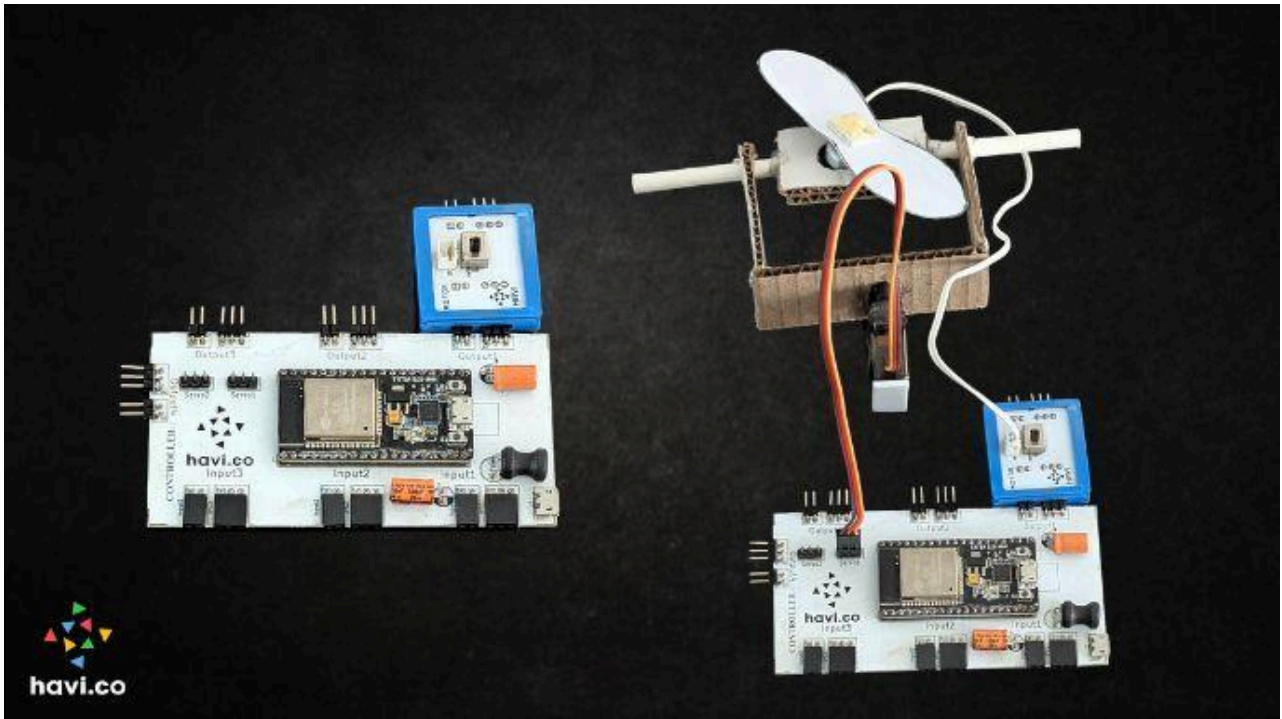

**Step 5** — Connect the controller with your computer/laptop using a data cable. Open [haviplex.com/micopy](http://haviplex.com/micopy) in a web-browser. Paste the code of the table fan project in the main.py file.

**Step 6** — Now, disconnect the controller from the laptop/computer and connect another power bank. Your table fan working model is ready.

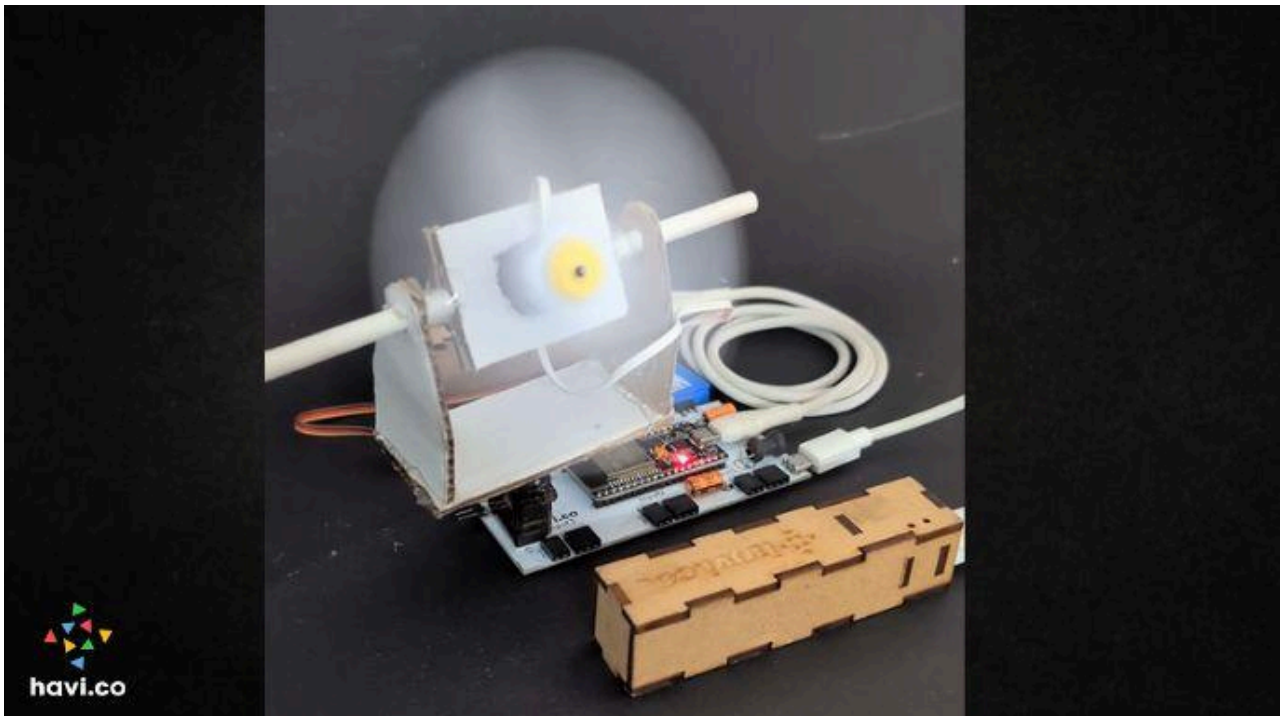

### How does a DIY Table fan work?

The logic is simple. The servo motor at the bottom turns at 180 degrees, which makes the stand turn right and left. The attached gearless motor rotates when the circuit is on. This way, it prototypes with an electric table fan project. Try this project by using Havi Elements DIY robotics starter kit & havi advanced kit add-on.

## Chapter 4

# How to make a pushup counter using python and Havi Controller

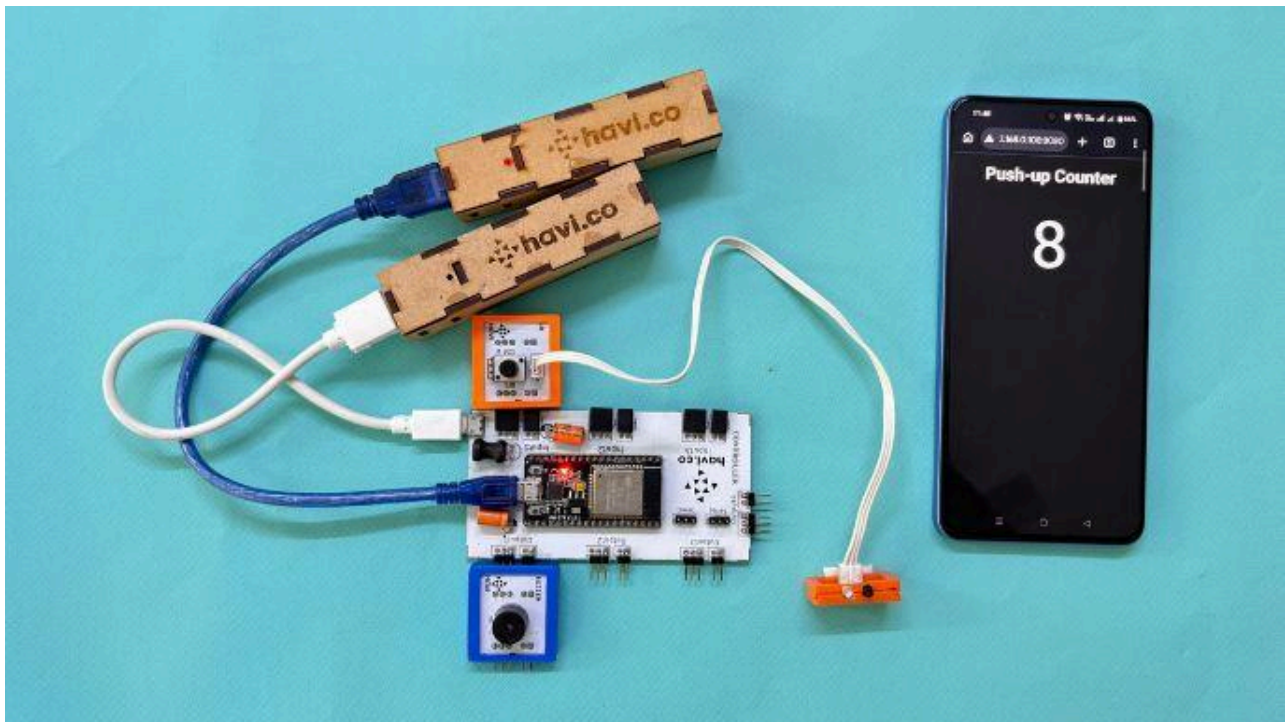
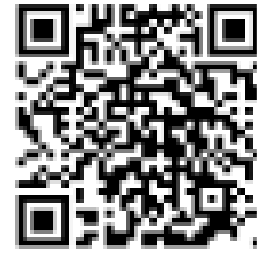

Regular exercise helps the body stay strong, active, and healthy.

Simple movements like stretching, jumping, or doing push-ups improve strength, balance, and energy. Exercise also helps children feel more focused, sleep better, and build confidence over time. When physical activity becomes a part of daily life, it supports both physical well-being and a positive mindset.

The push-up counter senses when someone moves down and pushes back up, observing the motion without getting in the way. There are no buttons to press or numbers to remember, just simple movement and steady progress. Each completed push-up is noticed and counted, making the exercise feel smooth and uninterrupted.

This simple system makes exercising easier and more enjoyable. Instead of worrying about counting in your head, you can focus on your movement and your strength. It helps children stay motivated, parents track progress, and families turn exercise into a shared activity. With every push-up, the counter encourages consistency, confidence, and healthy habits, making fitness feel fun, achievable, and rewarding.

In this blog, we are going to make a pushup counter system, using the IR Element, Havi controller (an esp32 based microcontroller, more powerful than arduino) and Python code. Get all the components from Havi DIY Robotics starter kit and Havi advanced robotics kit add-on. Or you can contact us to get these project-specific components.

Let's start.

## Things you need

Elements	Accessories	For programming
Havi Controller IR Element Buzzer Element	Power bank - 2 USB Cable Data cable 3-pin cable	Laptop/computer with active internet connection Havi MicoPy Mobile phone(optional)

## How to make

**Step 1** — First, let's make the circuit. Snap IR Element at input 1 port of Havi Controller. Snap Buzzer Element at output 1 port of Havi Controller.

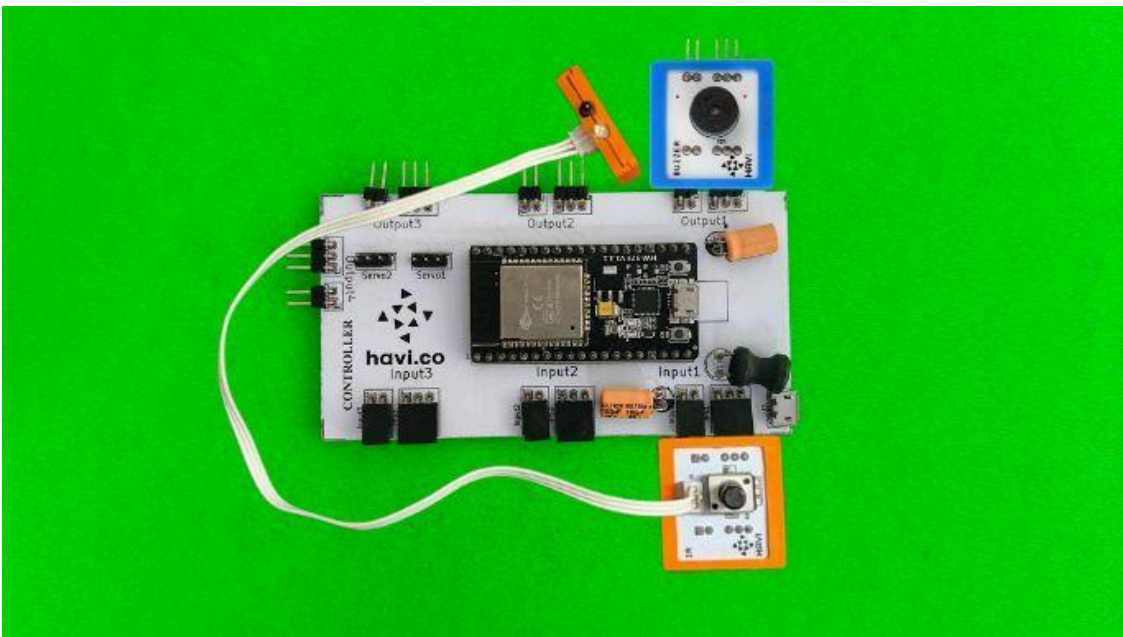

**Step 2** — Connect the Havi Controller to the laptop/desktop using data cable & connect the power bank with the Havi Controller using USB cable.

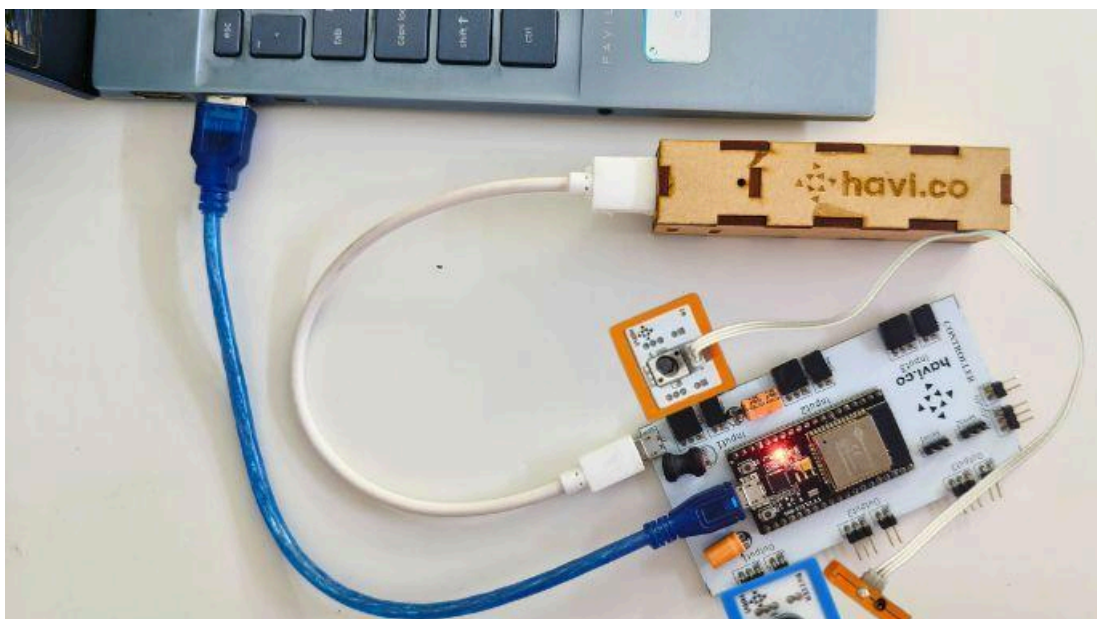

**Step 3** — Open your web browser and search for Havi MicoPy. Connect your Havi Controller with Havi MicoPy.

**Step 4** — Once Havi Controller is connected with Havi MicoPy, paste the code for pushup counter in the main.py file. Download the python code by clicking on the following button.

**Step 5** — Once you paste the code to the main.py file, change the wi-fi settings as per your wi-fi.

```
8
9 # ===== IMPORTS =====
10 from havi import ports
11 import time
12 import network
13 import socket
14
15
16 # ===== WIFI =====
17 WIFI_SSID = "YOUR_WIFI_NAME"
18 WIFI_PASSWORD = "YOUR_WIFI_PASSWORD"
19
20
21 # ===== HARDWARE =====
22 ir = ports.input1('ir')
23 buzzer = ports.output1()
```

Change here

**Step 6** — Run the code. The following should be displayed in the terminal, then open the generated server address in a new tab.

```
> Terminal
mode:DIO, clock div:2
load:0x3fff0030,len:4892
ho 0 tail 12 room 4
load:0x40078000,len:14896
load:0x40080400,len:4
load:0x40080404,len:3372
entry 0x400805b0
Open: http://[redacted]
Web server running
```

Open the address you get here in the new tab

**Step 7** — Once the web server tab will open, the count will automatically start at 0. To test, keep your hand near the IR LED and see the count will increase by 1 and buzzer will beep. Watch the following video. Your pushup counter is ready. Use another power bank with the controller to make the device free from laptop/computer. Now, copy the web address and paste it into the browser on your smart phone. The phone should be connected with the same wi-fi. Tada... you can display the pushup counts on your phone. Now, set your posture and start doing pushups. To reuse or log a new count, press the EN button on the controller. This way, you can make your own exercise tracker using Havi's advanced robotics kit add-on.



## Chapter 5

# DIY Automatic Sanitizer Dispenser

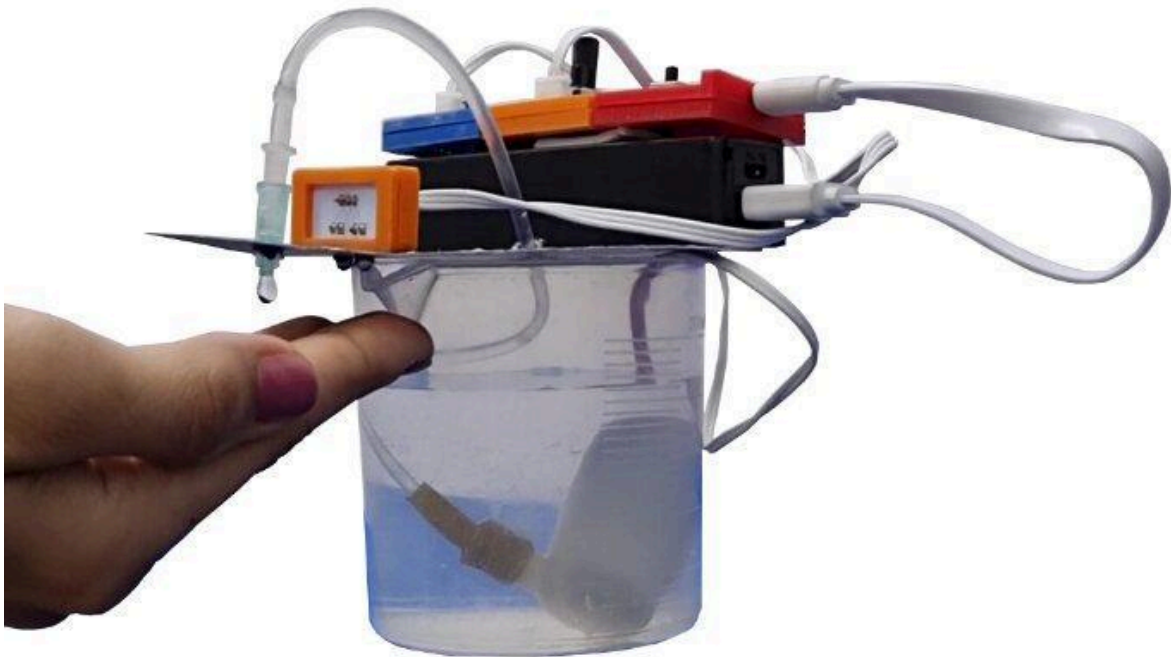

What makes learning fun, you ask?

Putting that learning into use. Seeing the learning come to life through creation.

The seeker's projects from Havi - DIY Robotics starter kit do exactly that, give kids an opportunity to convert what they learn into a functional thing.

The touchless automatic sanitizer is a simple dispenser that uses IR sensors to detect the presence of a hand and activates a motor pump to dispense the sanitizer.

So let's start

### Purpose:

- To stimulates curiosity & creativity in kids
- Provide hands On introduction to Electronics
- Brings a sense of achievement

## Things you need

Elements	Accessories	Craft material
Power IR with IR LED Motor	A water pump A bowl/container	Card paper Pencil Scissor

## How to make

**Step 1** — Make a circuit using Power + IR + Motor element.



**Step 2** — Attach the pump to the motor element and put the pump inside the water as shown in the images. Initially, we will take water to experiment.



**Step 3** — Cut the chart paper in a creative way. Make four small holes in chart paper to place a water outlet and IR LED.

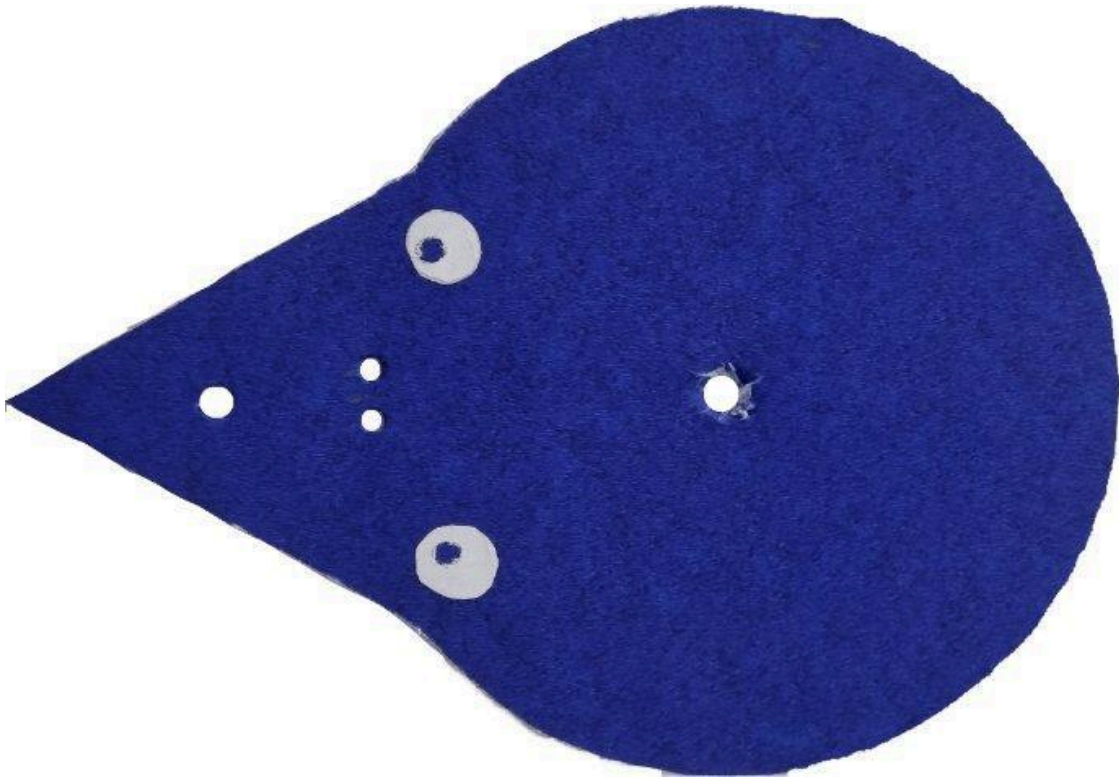

**Step 4** — Cover the container with chart paper in such a way that the water outlet and IR LED can be placed in the same direction.

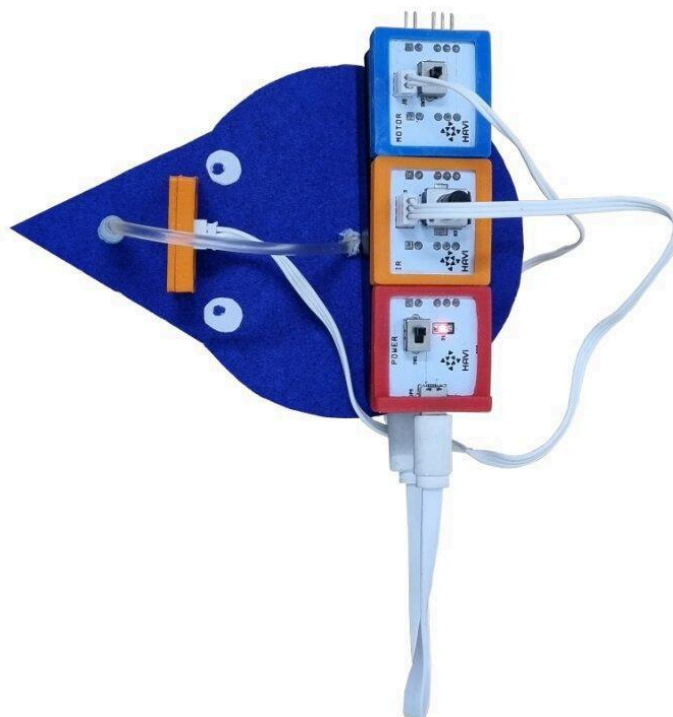

**Step 5** — Keep your hand under the pump outlet and Tadaa, your DIY touchless dispenser is ready! Replace the water with sanitizer now and surprise your guests. Observation & Conclusion: How does the dispenser know when to dispense the sanitizer and when not to? The IR sensor we installed senses the palm when we place it under.

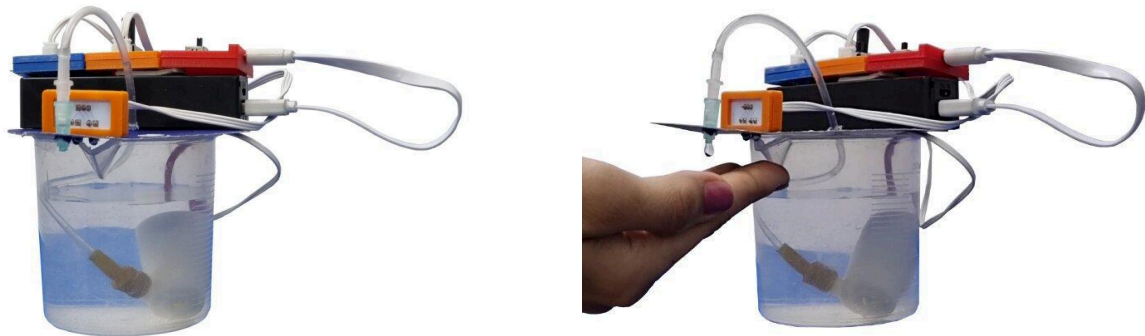

### **What is an IR sensor and how does it work?**

The IR sensors detect the objects in its surrounding either by emitting or detecting the IR radiations.

### **Working of IR sensors**

IR sensor consists of 2 things – IR receiver and IR transmitter

When the IR transmitter emits radiation, it reaches the object and some of the radiation reflects back to the IR receiver. That reflection confirms the detection and gives us the output or the beep. Know more here.

### **Great that the IR sensor detects our hands. But how will it activate the pump?**

Here is a simple diagram to explain that

When the IR sensor detects a hand, it pings the motor driver and wakes it up. Then the motor driver tells the pump that there is a hand waiting.

The pump will send the sanitizer up the tube and into the hands.

And all of this is powered through the power jack which is connected to the socket.

Get the exclusive pack of Havi elements & accessories to make automatic sanitizer dispenser project model, contact us to know more.

## Chapter 6

# Accident prevention system for hairpin bend zone in hills



Observing problems and trying to find a solution for it is one step towards creating a genius.

Ever thought of how safer it would be by knowing if there is another vehicle coming from the other side of a blind corner? Let's explore a common problem which we face while driving in hilly areas.

### Accidents at Hairpin curves in hilly areas

Almost at any hill-stations you would have seen blind zones or hairpin zones. The road takes a very sharp turn and due to the hill in-between, it's impossible for the vehicle driver to see what's coming from the side. That causes fatal accidents in many cases and causes lives.

While Mitthu was travelling with his family, he observed these blind zones and hilly areas and made up his mind to find a solution to this problem.

Accident prevention system in hilly area blind zones

Mitthu discussed the problem with Misari.

What if we make a sound and light as a warning for the driver that something is coming from the other side? Misari suggested.

Wow! But, how? Mitthu was excited and perplexed at the same time.

Using an IR Sensor! Misari revealed the game plan.

WOW - yes we can. Misari and Mitthu started working to make a working model of Accident prevention system in hilly areas' blind corners.

So put your creative hats on and see how we can make use of our Havi Elements to create a solution for this. Everything you need to make this project can be found in 2 boxes of Havi Elements - DIY Robotics Starter Kit, OR 2 boxes of Havi Elements - DIY Object sensor projects kit (without LED though) You can have one of each as well. Or you can contact us to order the customized pack for making this project.



## Things you need

Elements	Accessories	Craft material
Power - 2 IR with IR LED - 2 LED - 2 Buzzer - 2	LED Cables - 2 Power banks with USB Cables - 2	Card board Color Waste newspapers Glue Rounder/Cutter/Scissors

## The making

This project is created in two sections:

- First we create the circuit using Havi Elements.
- Second, we create a blind turn scenario using our crafting skills.

### Section 1: Creating the circuit.

IR (Infrared) sensors are used to detect the presence of the object. Checkout How IR works for more details.

Coupling IR sensor with Buzzer and LED will make the buzzer emit sound and LED glow whenever an object is detected by the IR Sensor.

Snap the elements to prepare the circuit as shown here.

Now your circuit is ready and you can check by keeping an object closer to the IR sensor if the buzzer and LED works well. You can adjust the sensitivity of the IR sensor using the controller provided in the element.



## Section 2: Creating a blind corner scenario.

A hairpin bend or blind corner in the hilly area is a turn on the road where the view of what is behind the corner is obstructed mostly by a hill. Sometimes even a building, or tree can also cause a blind spot. Warning signs are often placed on such roads to warn traffic.

You can watch the videos and photos provided in this blog and also search for other images of blind corners over the internet and create a craft model to demonstrate the working.



**IMPORTANT:** Note the placement of the IR Sensors and the associated buzzers and led lights in your model.



Once you have created the scenario, get two toy cars and demonstrate the working.



Get the customized kit to make this project, contact us with the project name to know more.

### **How does it work?**

The IR sensors are placed on the left lane of each side of the curve.

As the car approaches the curve, it is detected by the sensors placed there and a notification LED glows on the other side of the curve with a buzzer sound to alert the traffic coming from that side about the approaching car.

This works on both the sides of the curve.

This notifies the driver about the vehicles approaching from the other side of the blind corner. The driver then can carefully take the turn and ensure a pleasant and safe journey.

Advantages when implemented in the real world

Accidents can be prevented and a lot of lives and loss of vehicles can be saved when implemented at hairpin curves in the real world.

You can get the components from two boxes of Robotics Starter Kit Or two boxes of this STEAM kit. Or can contact us to inquire for the kit.

Keep creating.

## Chapter 7

# How to make a line follower robot

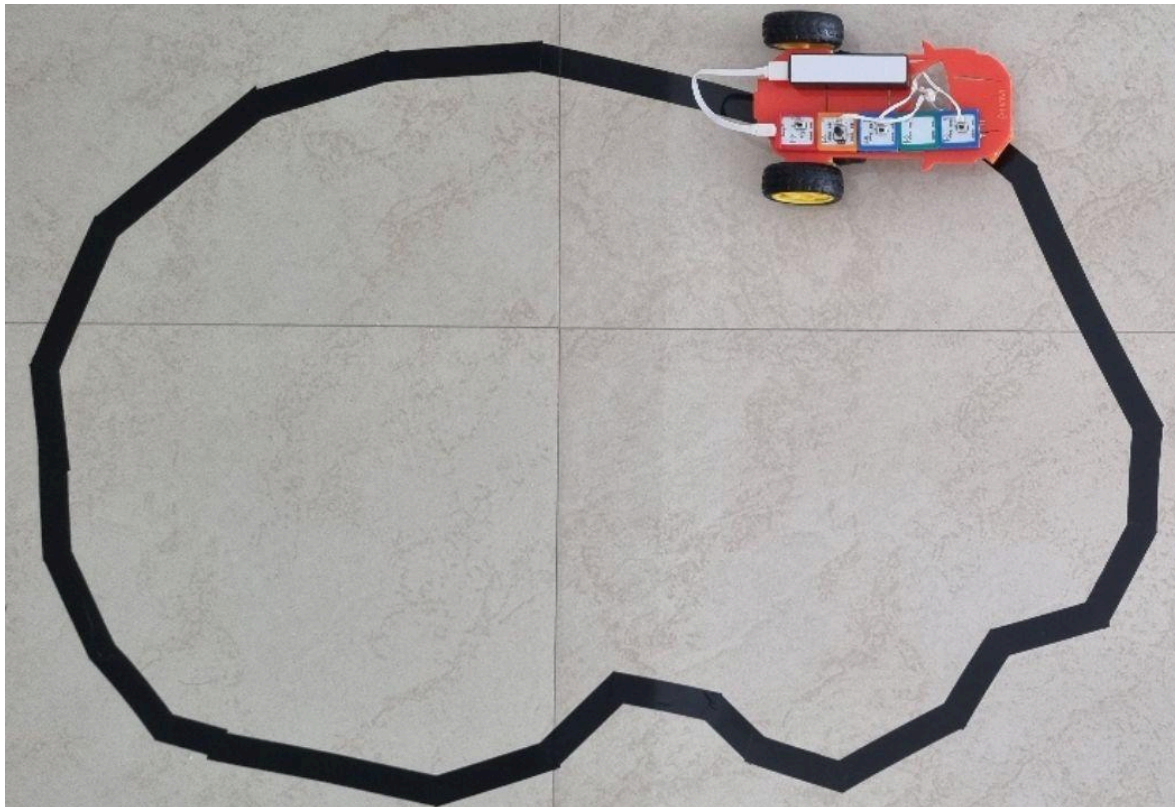

A line follower robot is a robot that follows a specific path drawn on the floor. We can call it a line following robot or a line follower car. In-fact this is an important milestone or project in anyone’s robotics learning journey.

We can make line following robots with and without arduino & coding. So let’s begin.

### Which sensor is used in a line follower robot?

An IR Sensor - Infrared sensor is used to make a line follower robot. We are going to discuss the working of a line follower robot with an IR sensor along with step-by-step making instructions and the science behind how a robot follows the line using IR sensor.

Use the following Elements out of Havi's DIY Robotics Kits. With this, even a 7 year old can make a line follower robot without the complexities of arduino and coding. Line follower robot project can be a good choice for school and science fair project as well.

### Things you need

Elements	Accessories	Craft material
Power Motor - 2 Flip IR	Car plate Power bank with USB Cable Geared motor - 2 Wheels - 2 Roller 3-pin cable	Double-sided tape Wire ties Black tape

## How to make

**Step 1** — Snap the circuit

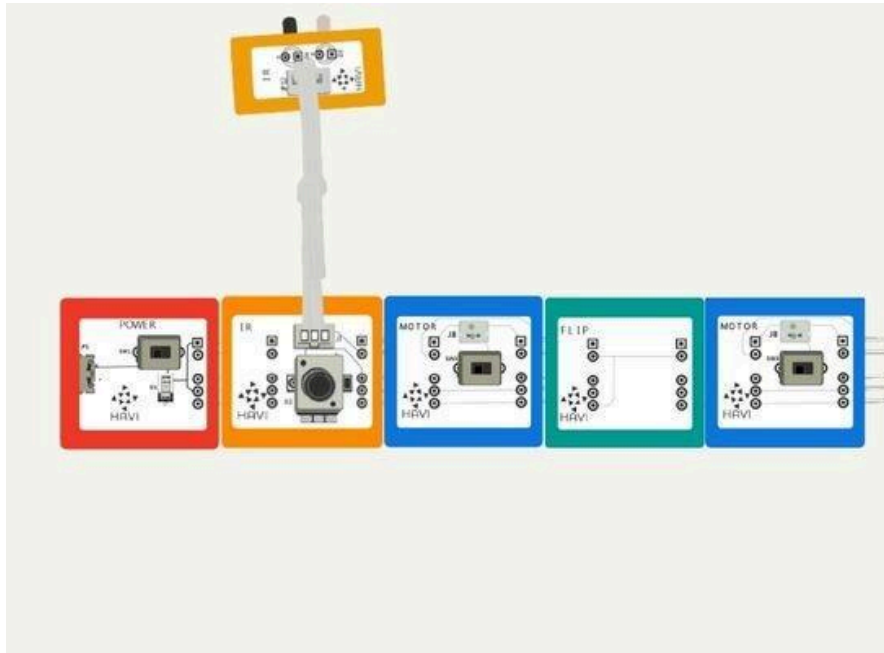

**Step 2** — Making a black line path. We can make a thick line on the floor using a dark black marker or can use black tape to create the path. The other way should also work. That means creating a white path on a black surface. Check out the picture for a reference of the path.

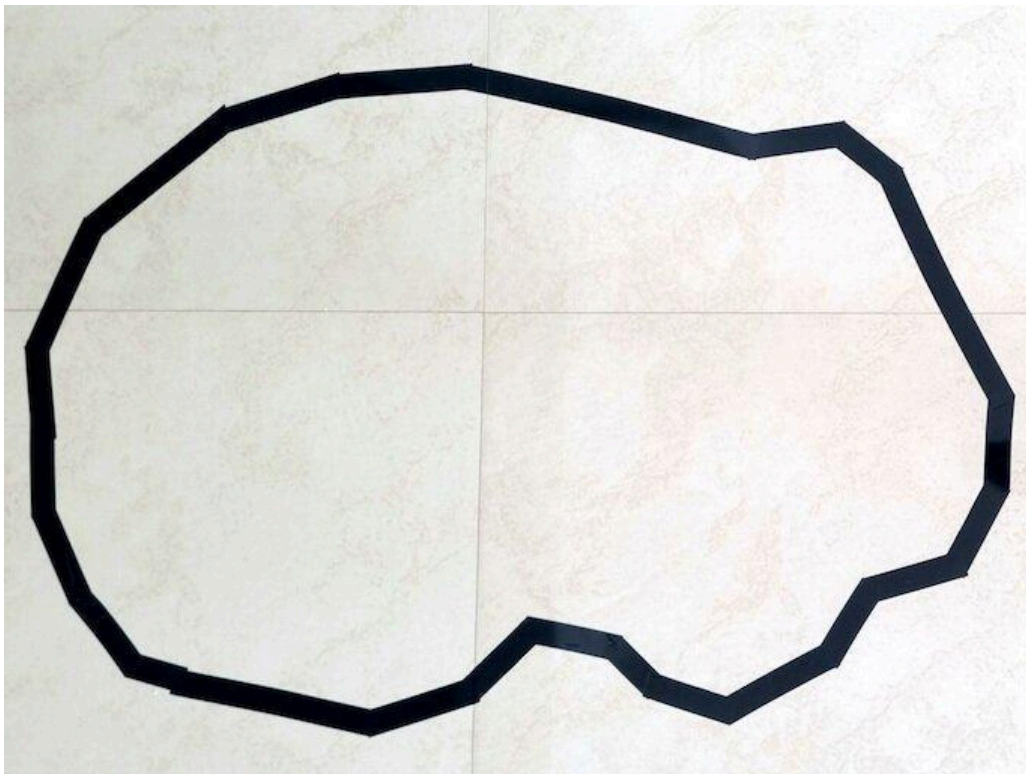

**Step 3** — Build a car Please refer to How to make a robot using Havi Element. Further we will convert this into a line following car.

**Step 4** — Place the circuit Stick the circuit on the car using DST and connect the motors.

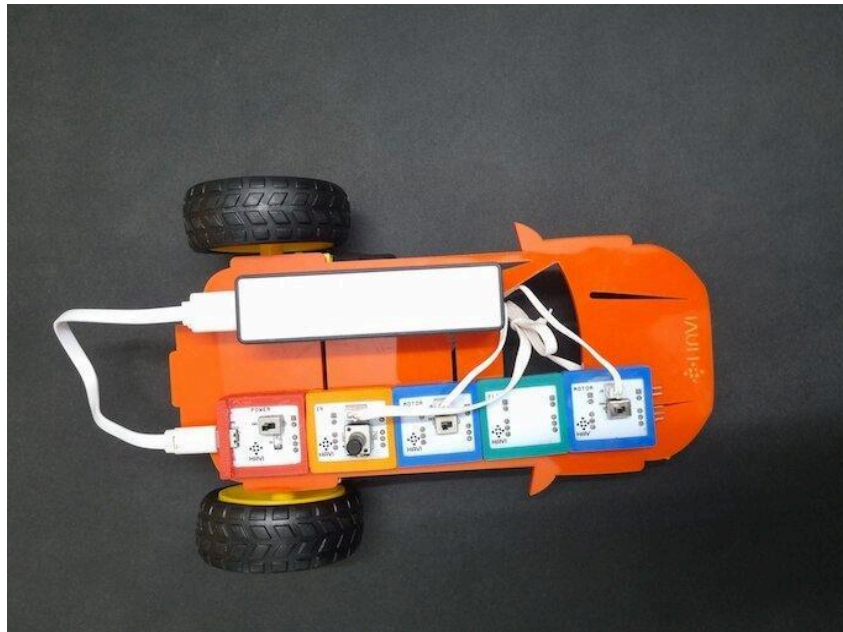

**Step 5** — Tune the IR element Tuning the IR sensor is the most important part of the entire line following car project. Rotate the potentiometer to tune the sensor. Place your car on the surface keeping the IR LED Element to face the black line. Keep tuning the sensor and adjust it in a way so it detects the low sensitivity and hence will start detecting only the black line. Your line following robot project is ready to travel on the black line path you have made on the floor.

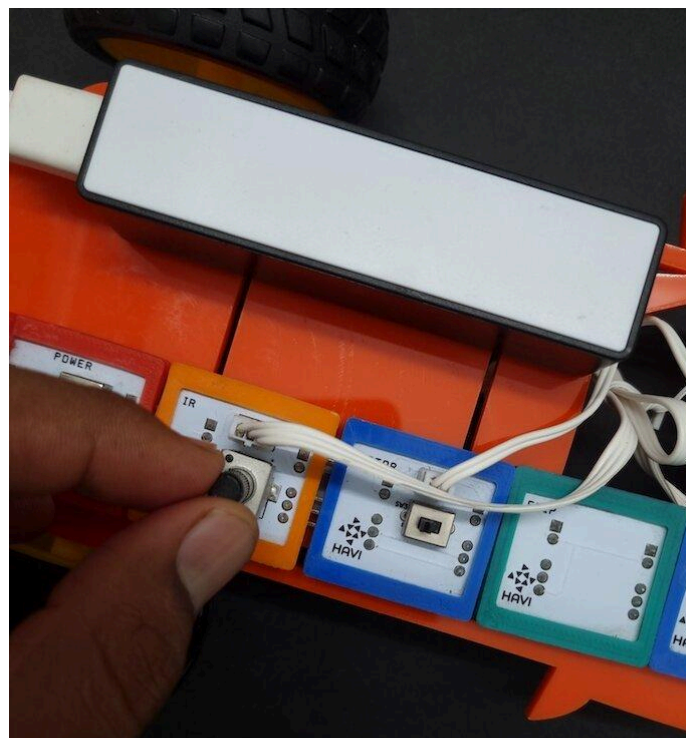

### How does it work?

We are using an Infrared sensor or IR element for this line following robot project. The sensor detects the IR light bounced back by an object to detect the object. Black color has a tendency of absorbing all the IR rays. Hence the receiver (the photodiode) in the IR LED element does not detect the IR rays.

We have two motor elements (and hence two geared motors) under the control of IR element.

- The motor X works when IR detects an object.

- The motor Y works On the Flip of IR,that means when IR does not detect an object.
- When IR says there is an object, the motor X will start and Y will stop.
- When IR says there is not an object, the motor Y will start and X will stop.

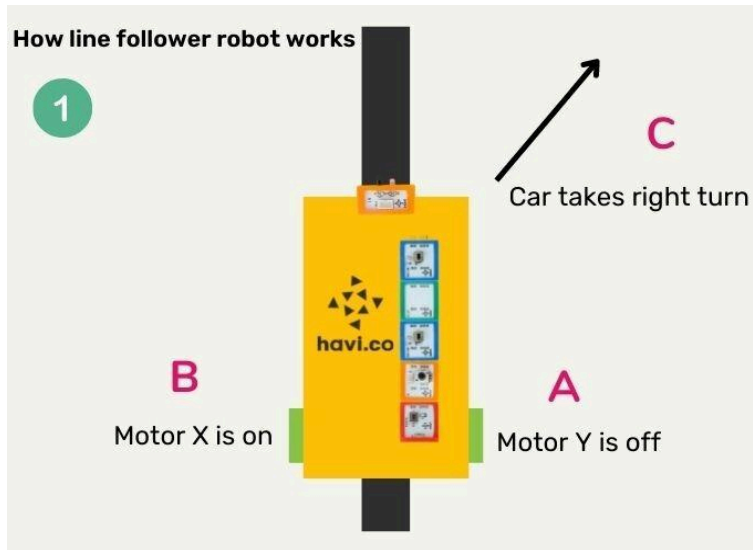

Now, what is the object here? The floor. The floor is the object which reflects the IR rays back but we have a black line on the floor that does not. Let's start with the IR LED element facing the black path. In this case, the IR will say no object (since the black path absorbs the rays) hence motor Y work and X will stop.

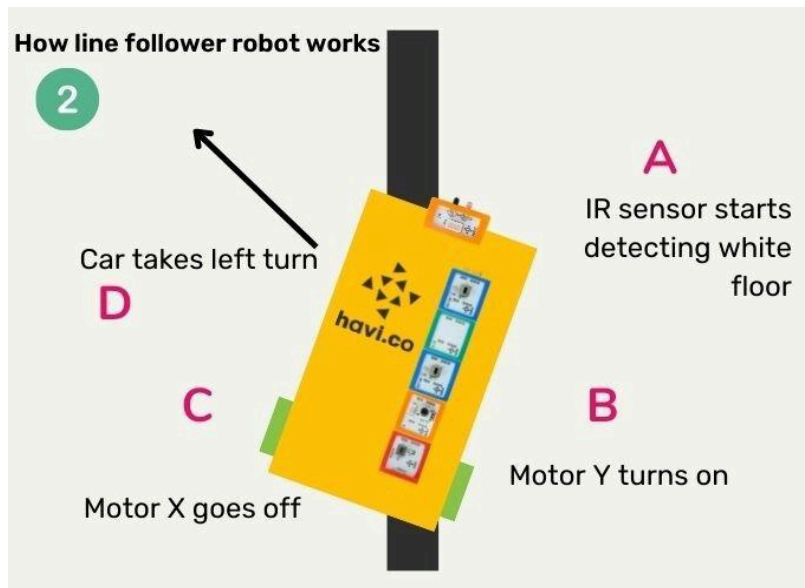

The car, being powered by a single motor, won't go straight and will take a turn which will take IR LED away from the black line focus. The moment it goes away, the floor will start bouncing back the IR rays. That will stop the Y motor and start the X motor. Making the car take a turn in the opposite direction. Bringing the IR LED onto the black path for a line and then going away in the opposite direction.

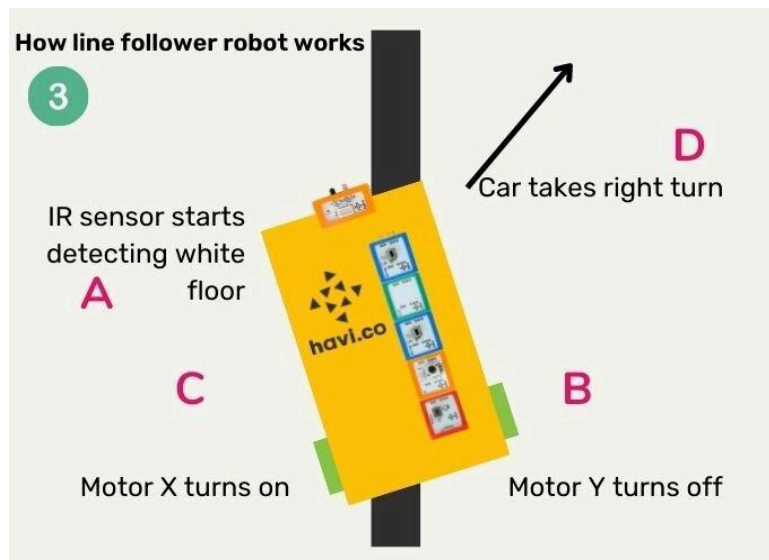

This will continue and the IR LED will keep offsetting towards the left and right side of the path being on the path. That's how your line following robot will finish the path. Caution: Line follower car will not work in the presence of sunlight, so stay away from sunlight while executing this project. (Why? Find answer in How IR sensor works)

**Uses of a line follower robot:** There are several domestic as well as industrial applications of the line follower car. Take for example we can make a line following robot that delivers medicine and food to the patients in hospitals, and serves in restaurants. A line follower robot can be used in factories to transfer goods from one place to another, without human interaction. This kind of robot can be useful in military applications as well. Now you can start making your own line follower robot and apply it somewhere. Make a line following the robot using Havi's customized pack. Contact us to know more.

## Chapter 8

# How to make an obstacle avoiding robot

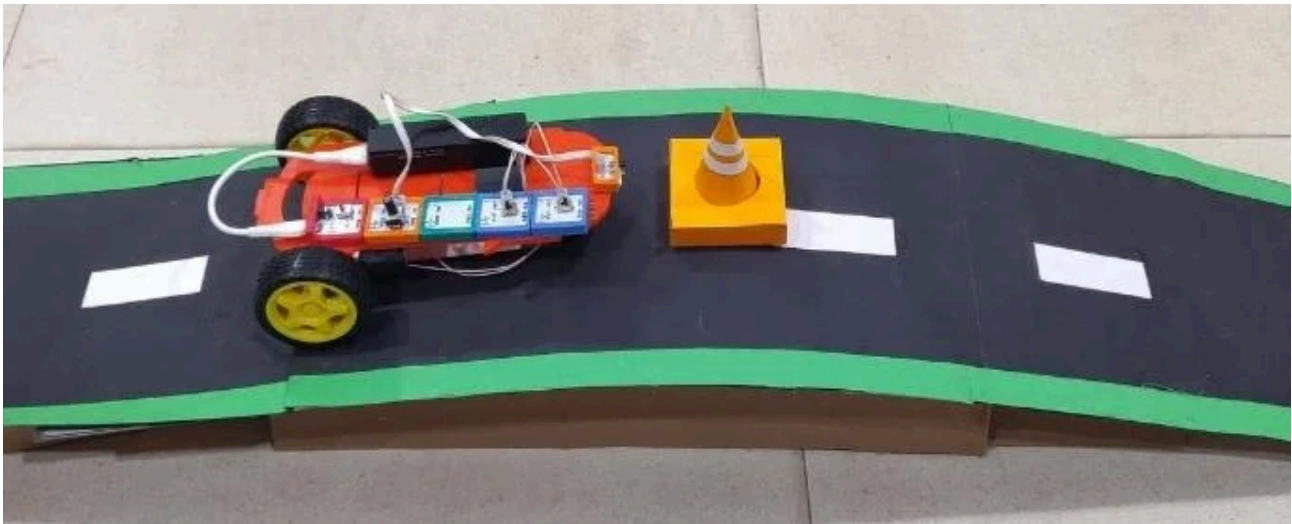

### What is an obstacle avoiding robot?

An obstacle avoiding robot or an obstacle avoiding car is a vehicle in motion that avoids colliding with an obstacle either by taking a turn or by stopping at the obstacle. This prevents the robots from causing damage and casualties.

### Which sensor to use to make an obstacle avoiding car?

Just to talk about the general practice, an obstacle avoider robot can be made using either of these sensors.

- IR sensor - Infrared sensor
- Ultrasonic sensor

Both of them work on different principles and the output of ultrasonic sensors would be more accurate in the real world.

However, for learning purposes, we will use an IR sensor that comes in the DIY robotic starter kit and DIY robot car kit.

### Things you need

Elements	Accessories	Craft material
Power Motor - 2 Flip IR	Car plate Power bank with USB Cable Geared motor - 2 Wheels - 2 Roller 3-pin cable	Double-sided tape Wire ties

There are two different functions an obstacle avoiding robot can perform.

- Stop the car if it detects an obstacle: The car or robot will stop and stand still at the obstacle. It will continue moving forward if the obstacle is removed, or if you change the direction of the car, towards a clear way ahead.

- Take a turn if the robot detects an obstacle: The robot will take a turn when it sees the object, to avoid a collision, and will continue moving in that direction until it sees another obstacle which makes it change the direction again.

## How to make

### Circuit for obstacle avoiding robot that stops at an object

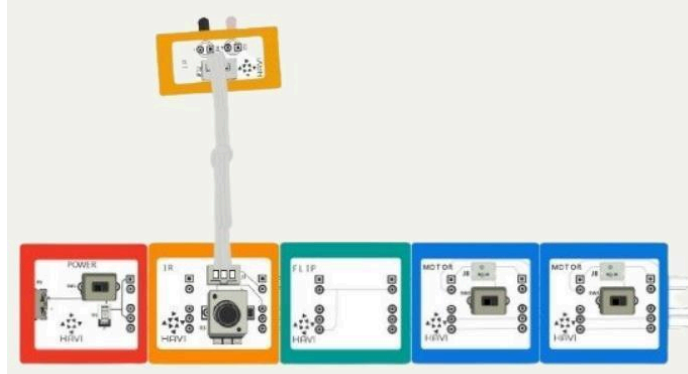

### Circuit for obstacle avoiding robot that turns at an object

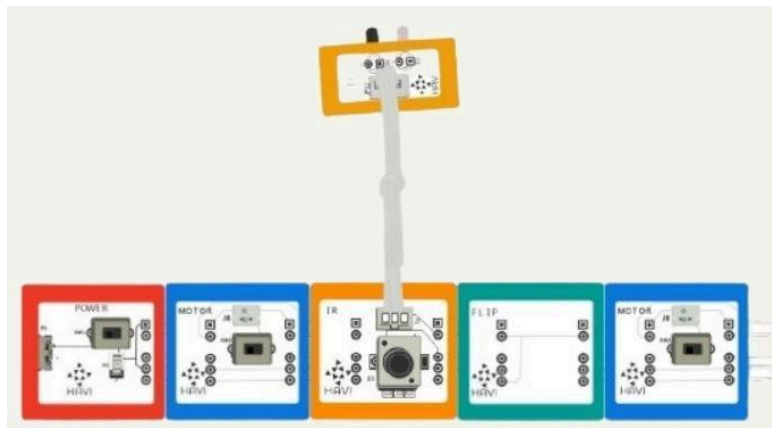

**Step 1 Make the car** — Please refer to How to make a robot using Havi Elements. If you are making an obstacle avoiding robot using Havi Robotic Car Kit.

**Step 2 Place the circuit** — Place the circuit on the robot using DST or elements hooks (if you are making it with the DIY robot car kit) and connect the motors.

**Step 3 Tune the IR Element** — Use the potentiometer to set the range of the IR element. Set the potentiometer so it detects the adequate distance. Keeping the sensitivity high should help as it will detect the obstacle at distance and will prevent a collision.

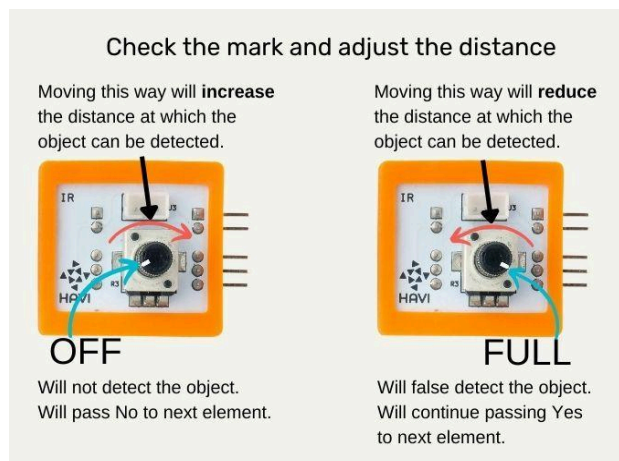

**Step 4 Execute your project** — The obstacle here can be any object like a wall, human, pets, books, or any other physical object that comes into the sight of the IR Element.

### How does it work?

#### Case of a robot that stops at an obstacle.

The Flip element between IR and motors will make the motors run in case there is no obstacle. So when the IR detects the object, the Flip will send a no command and the motors will stop rotating. That makes the robot stop.

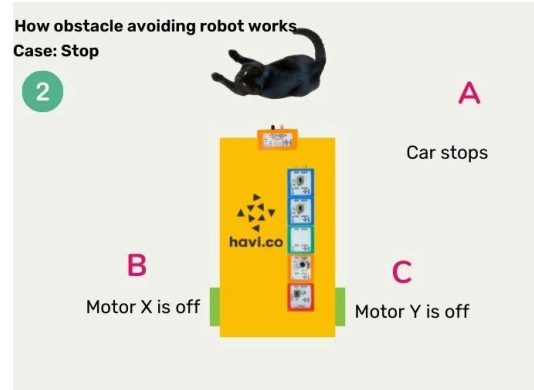
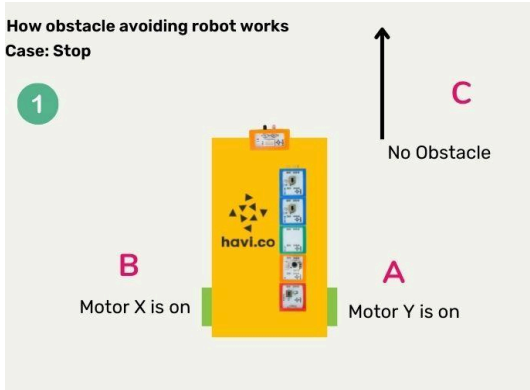

#### Case of robot that takes a turn at the obstacle.

Here one of the motors is out of IR control and which will continue rotating, irrespective of the presence of an obstacle. But another motor, under the control of IR and flip, will stop at an obstacle. That makes the car take a turn.

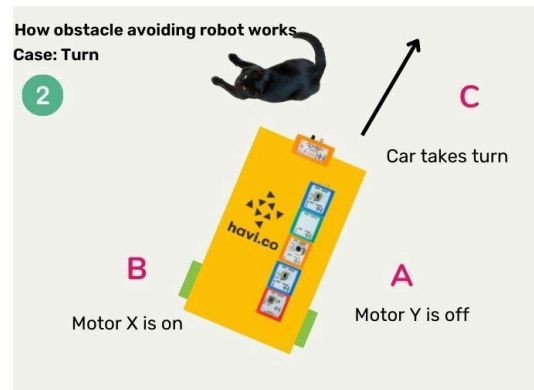
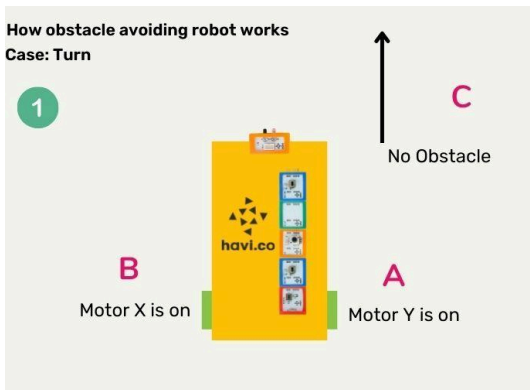

#### Applications of obstacle avoiding robots.

For a smart autonomous car, obstacle avoidance is the top most feature to keep the passenger safe.

The same is the case for robots.

Avoiding obstacles is the most important and common feature of all the smart cars and robots that are in motion.

Now try building one and experience it yourself. Contact us to get the customized pack.

## Chapter 9

# DIY Train collision avoidance system using Havi Elements

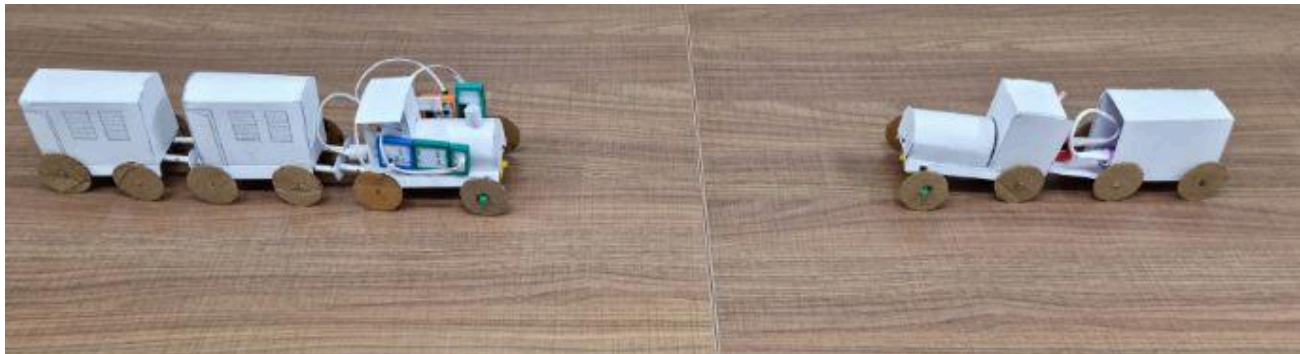

Trains could have been the safest way to travel because they run on the rails, a defined path. But that very path has caused some of the major accidents in the history of transportation. There are multiple types of train accidents and one of the major is a train's collision with the other.

Yes, it has happened several times in history that two trains come from opposite directions at the same time on the same track and collide with each other. That has caused deadliest accidents claiming several thousand lives.

Eventually train running institutions across the world have designed several train accident prevention systems. One of the most recognised is the "Train Accident Collision System" or TACS, designed by Indian railways.

TACS uses radio frequency and GPS together to prevent train collisions.

The technology is very advanced and promising.

But we can create our own working model of the train accident collision system using Havi's robotics kits too!

Yes, we can use IR sensors to prevent train collisions. Let's see how.

### Things you need

Elements	Accessories	Craft material
Power - 2 Motor - 2 Flip - 2 IR - 2	Wheels - 4 Geared motor - 2 Power bank with USB Cable - 2 3-pin cable	Double-sided tape Card papers

### How to make

**Step 1 Craft your trains.** — Prepare trains using card board or construction papers as per your choice and design thoughts. You can refer how to make DIY train using Havi Elements & paper craft.

**Step 2 Use of geared motors and havi elements** — You need to power your trains using geared motors supplied with Havi Elements. Hence should use at least one motor and two wheels for the train. Rest can be card board wheels.

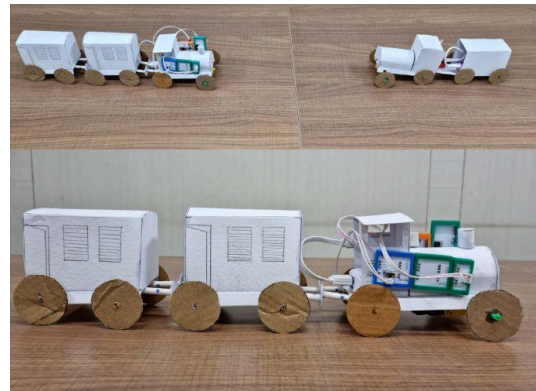

**Step 3 Test your trains** — Use Power - Motor circuit and plug the geared motor into the motor element. Turn on the power element and make the train run on a surface.

**Step 4** — Now, you can update the element circuit in both the trains to the following: This circuit will stop the motor when there is an object in front of it. Place the IR LED at the front side of your train engine, so that the LEDs face the front. Turn the power on and test your train. If you keep your hand in-front of IR Element the train would stop. As you take the hand away, the motor will turn and the train will Start moving. Tune the IR element using potentiometer to detect the object at maximum possible distance. Know how IR sensor works. You can now keep the trains in front of each other so that their IR LEDs point each other. Turn the power on for both the trains and the trains would start moving. As they approach each other, the IR signals the train A will stop the train B and vice versa. Check the video here. This can be a playful toy at home and a wonderful project for science projects. Do it and share your work with everyone.

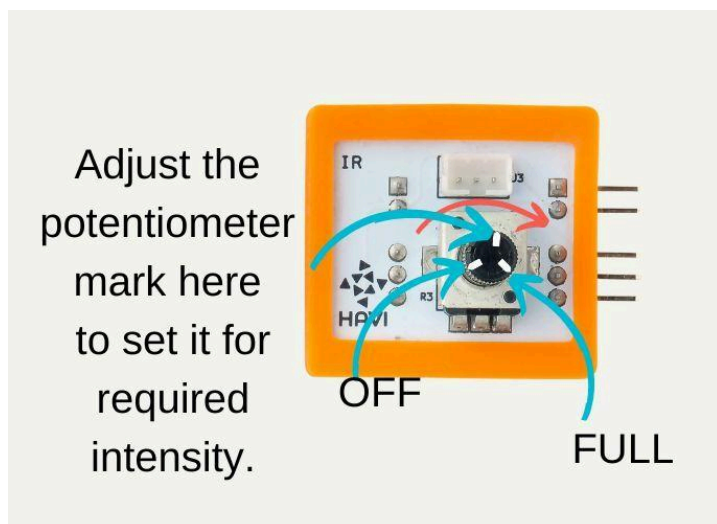
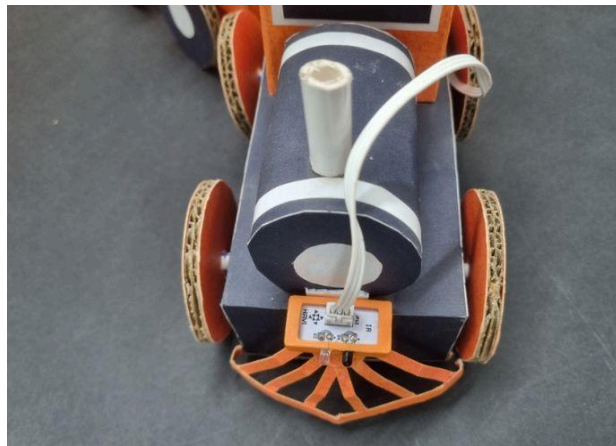
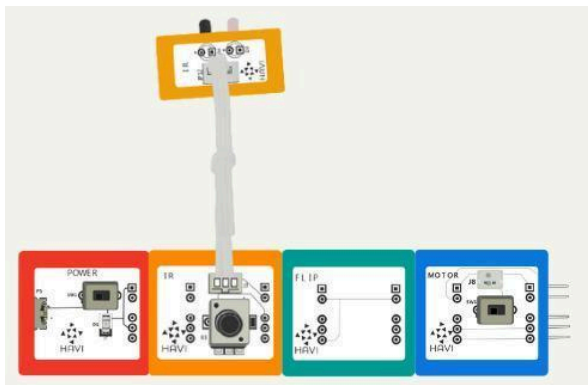

## Chapter 10

# How to make an edge avoiding robot



### What is an edge avoiding robot?

An edge avoiding robot is a robot that runs on a surface like a table and can effectively detect when it reaches the edges or cliff of the table. As it approaches the edge, it will change direction to avoid falling from the table. It will follow and walk only on the boundaries of the table.

So let's begin.

### Which sensor is used in an edge avoiding robot?

Usually, any of the following two sensors are used to make an edge avoiding car.

- IR sensor - Infrared sensor
- Ultrasonic sensor

An IR Sensor uses infrared light while an ultrasonic sensor uses sound waves to detect an object. Here we are considering the table surface as an object and tuning our sensor to follow it.

For this project, we will be using just one IR sensor to avoid the edge of a table.

We are going to discuss the working of this in detail further.

### Things you need

Elements	Accessories	Craft material
Power Motor - 2 IR	Car plate Wheel - 2 Geared motor - 2 Power bank with USB Cable Roller 3-pin cable	Double-sided tape Wire ties Ice cream sticks

## How to make

### Edge avoiding robot circuit

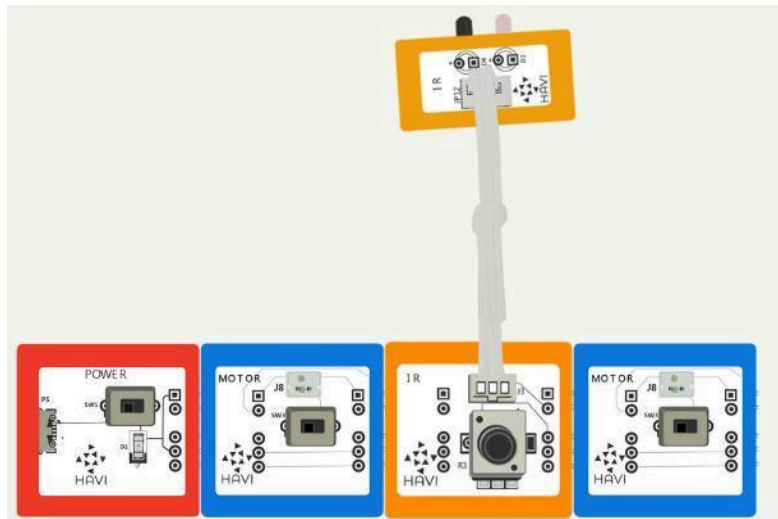

**Step 1** — : Set up a table Clean a table and set it up for the experiment.

**Step 2** — : Build a car as structure of robot For DIY Robotics starter kit users.

**Step 3** — : Place the circuit Stick the circuit on the car using DST and connect the motors. Follow the user manual for circuit placement if you are using a DIY robotic car kit. Further, we will communicate considering starter kit users in mind. Robotic car kit users can follow the same.

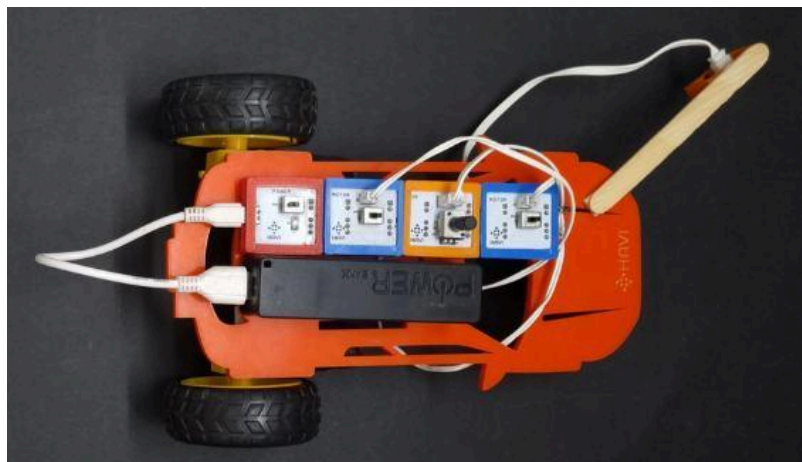

**Step 4** — : Tune the IR element Tuning the IR sensor is the most important part of any creation using an IR Element. Rotate the potentiometer to tune the sensor. Keep the mark of the potentiometer in the center. Your edge detection robot is ready to travel.

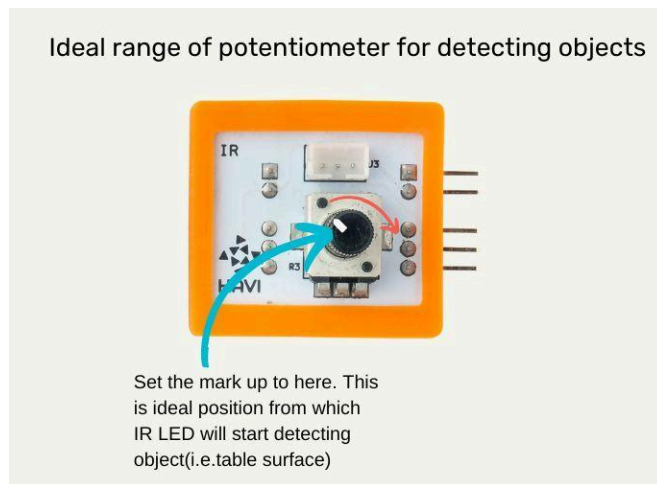

### How does it work?

We are using an Infrared sensor or IR element for this edge avoiding robot car project. The sensor detects the IR light bounced back by an object to detect object. Refer to How IR sensor works to know more about working on IR Elements.

We have two motor elements (and hence two geared motors) among which one is under the control of the IR element.

The motor X is always on, so one wheel connected with motor X will always rotate. The motor Y works under the control of the IR Element.

When IR says there is an object (table surface), motor Y will start. When IR says there is no object (approaching the edge of the table), motor Y will stop.

Case:1 When IR LED detects the edge(i.e. object)

Output: The car will go straight

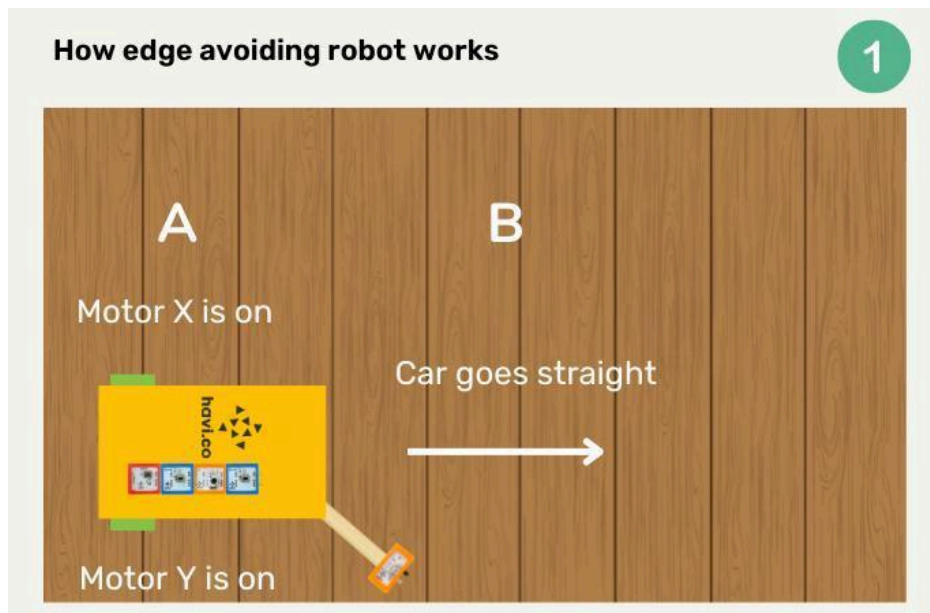

Now, what is the object here? The table surface. As long as the IR LED detects the table, motor Y will be ON and the car will go straight.

Case:2 When the IR LED goes outside the table surface(i.e. No object there)

Output: The car will take a turn

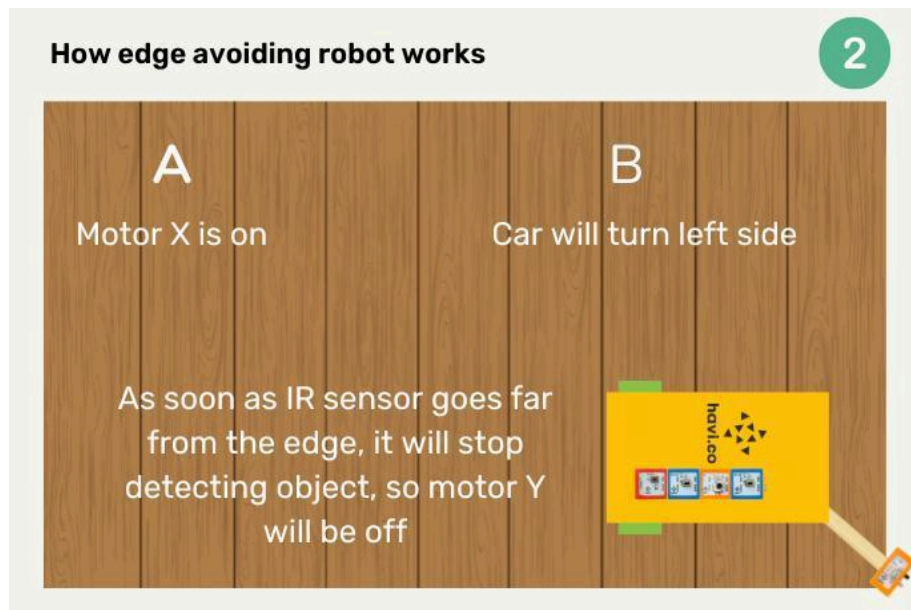

As soon as the IR LED stops detecting any object, motor Y will stop. The car, being powered by a single motor, won't go straight and will take a turn which will bring the IR LED on the table surface again. IR LED starts detecting the table edge again and motor Y will start and the car starts moving straight again.

Case:3 When the car takes a turn and IR LED comes again on the table surface

Output: The car will go straight

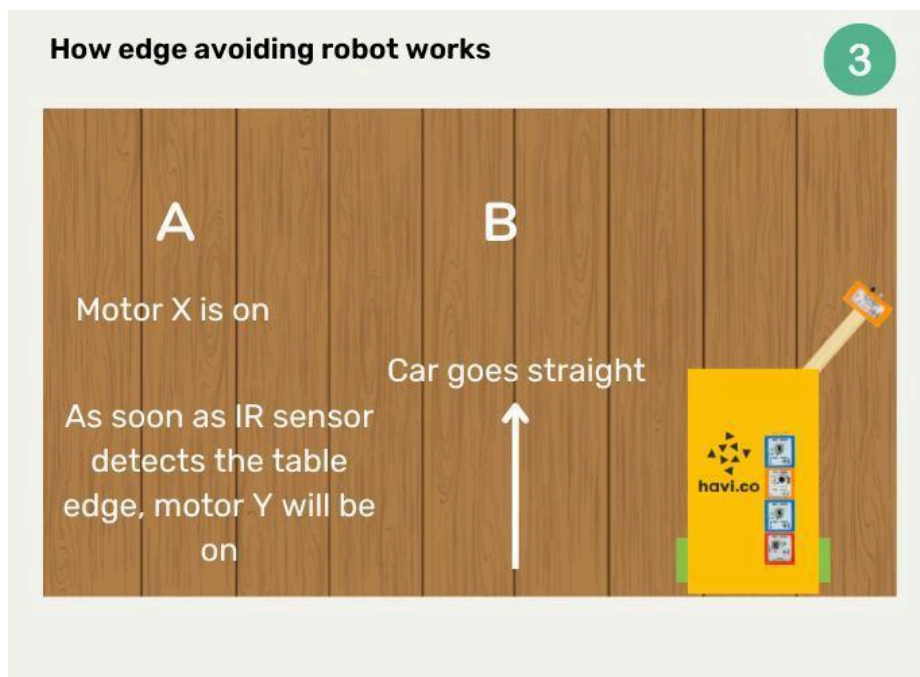

This will continue and the IR LED will keep detecting/not detecting table edges and so the car will take turns on the corner of the table and keep moving on edge of the table.

That's how your edge avoiding robot will finish the path.

### What is the use of an edge avoider robot?

The edge avoiding feature can be very useful for a robot or a car to prevent accidents in the industrial, domestic, transportation, and military applications of moving robots.

Also read [How to make an obstacle avoiding robot](#) [How to make a line following robot](#)

**Chapter 11**

# Make a moving solar system working model using Havi Elements

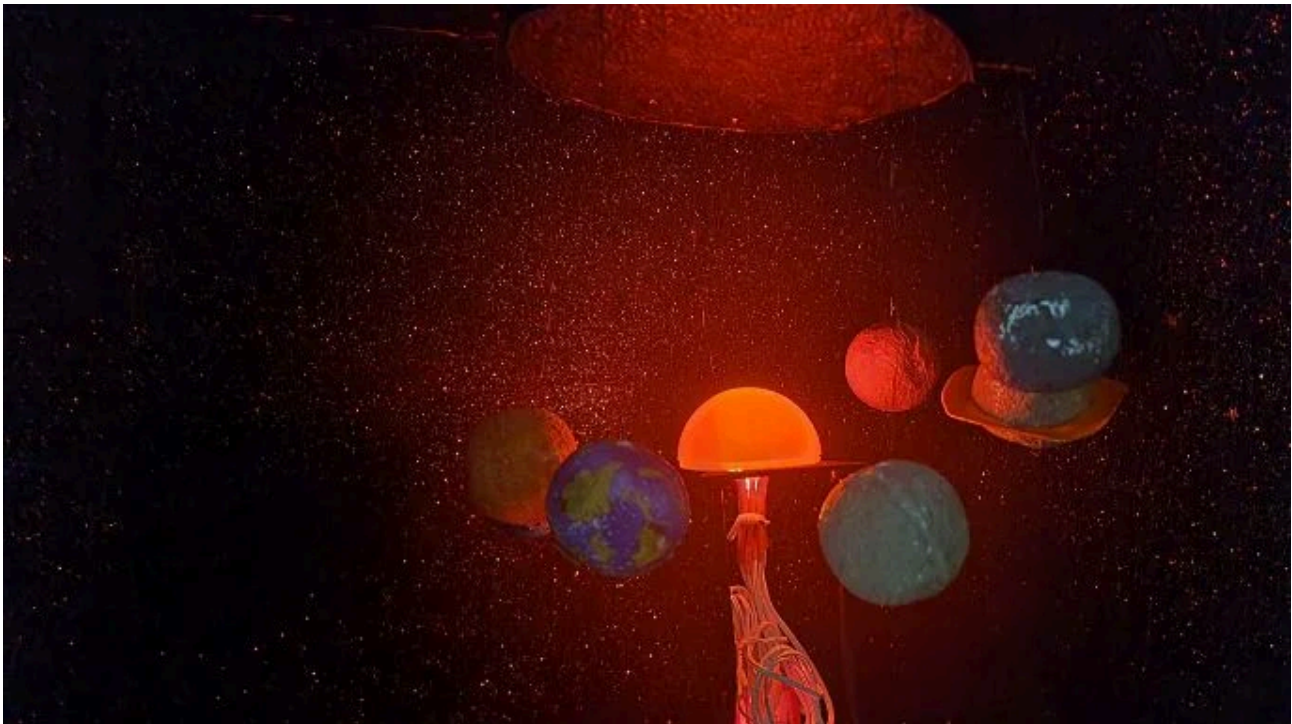

Do you know Kiyan? Kiyan is a 4th grade student who loves to create things. His parents have bought him a pack of Havi's DIY robotic starter kit.

One day he nominated himself to the school science projects fair and submitted a proposal to make a moving, rotating solar system working model.

The parents were happy and a few friends were skeptical.

But he did it finally and we at haviplex.com are proud of him. Hence, we decided to document his work into a blog post and share with everyone.

Here is how Kiyan made his solar system project with photos and videos. Know how he has done and do it your own way.

### Things you need

Elements	Accessories	Craft material
Power - 2 Motor LED - 2	Power bank with USB Cable - 2 Red LED Cables - 6 Yellow LED Cables - 2 Wheel Geared motor	Thermocol sheets Thermocol balls Large box/cardboard tripod Small box Bulb head Black sheets Glitters & stars Thin coil wire Skewers

### Important Notes

The elements and accessories required for these projects can be managed in following ways.

1. With Havi - DIY Robotics Starter Kit and DIY Robotic Car Kit. But you will need an extra power element, power bank, usb cable, LED element and LED cables. You can buy them separate OR you can use something else, like a regular torch to make the sun. 2. If your school/institute has Havi's kits in the robotics lab, you would have multiple elements there. Just use and enjoy. Take necessary permissions though.

3. The Geared motors in the kits as designed to power the cars, hence are faster for solar system. You may need a very slow motor. Please contact us for same.

4. You can contact us to get the customized pack of making moving solar system project model.

## The making

**Step 1** — Use 8 different thermocol balls to make planets. Color them well and make the rings of Saturn.



**Step 2** — Get or make a box and paint it black. Can use black sheets too, instead of color. The size of box Kiyam has used is provided here for reference.

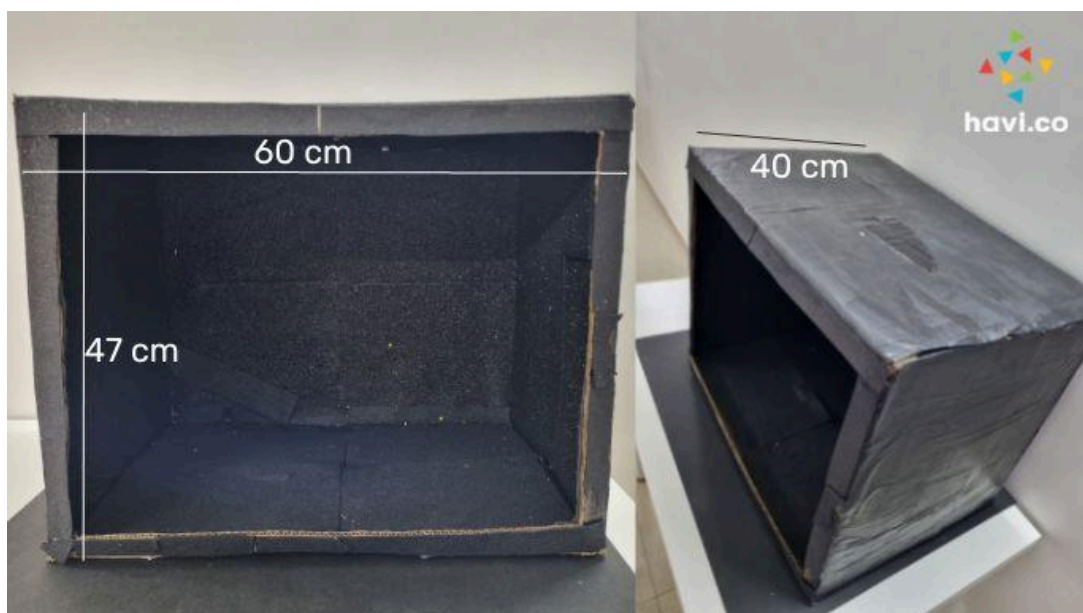

**Step 3** — Cut a disc with 20 cm diameter out of a thick (at least 5 cm) thermocol sheet. Color it black.



**Step 4** — Remove the wheel grip. We need only the yellow ring for the project but keep the grip safe. Need to cover the wheel back with grip after the project.



**Step 5** — Make a round cavity into the middle of the thermocol disc, so that the wheel fits inside the cavity till half way. You can wrap the wheel ring with DST before inserting to make the bond tighter.



**Step 6** — Pierce through the thermocol balls using a skewer and pass a piece (around 20 cm long) of coil wire through it. Make a knot so the wire does not come out. Tie the other end of the wire with the skewer's non-pointing side.

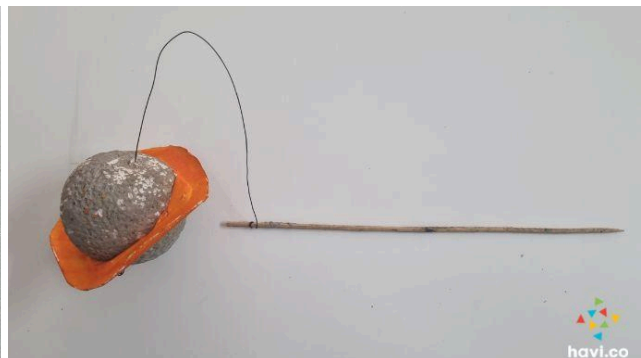
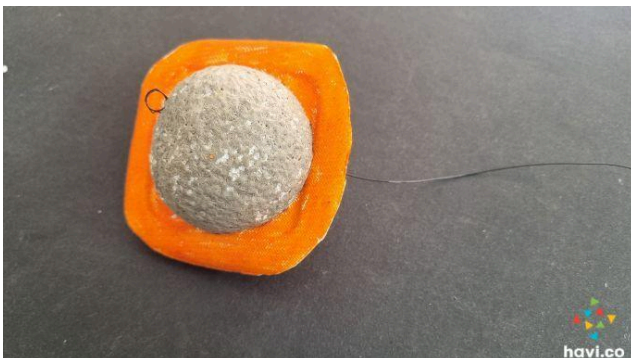

**Step 7** — Insert the skewers one by one into the thermocol disc. Keep the balls at different height and also insert the skewers up to different depths to make the orbits realistic. Color the skewers and wires to black.



**Step 8** — Pierce a hole into the box top at middle-center. Place the geared motor and stick with DST so that one shaft passes through the hole and would be visible from inside of the box.

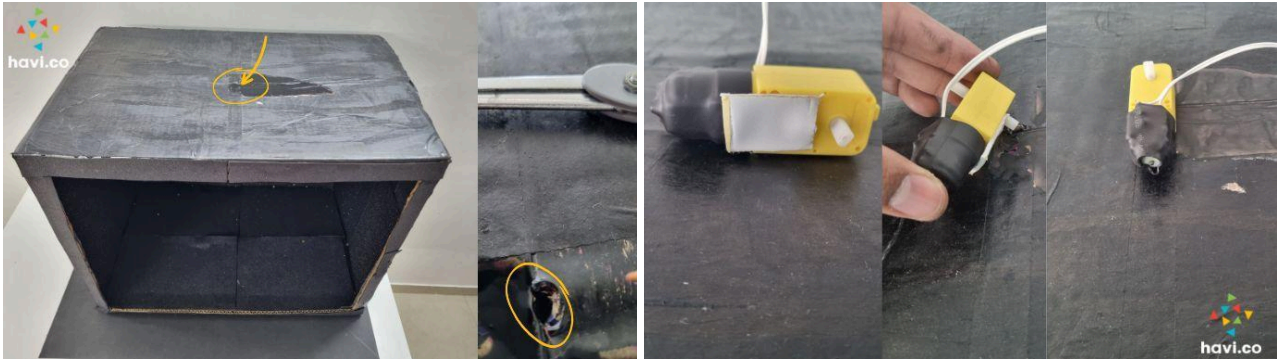

**Step 9** — Make the Power-Motor circuit and connect the geared motor with the motor element. Turn on the power element just to check if the shaft is smoothly rotating within the hole. Hole should be big enough for the shaft to move smoothly.

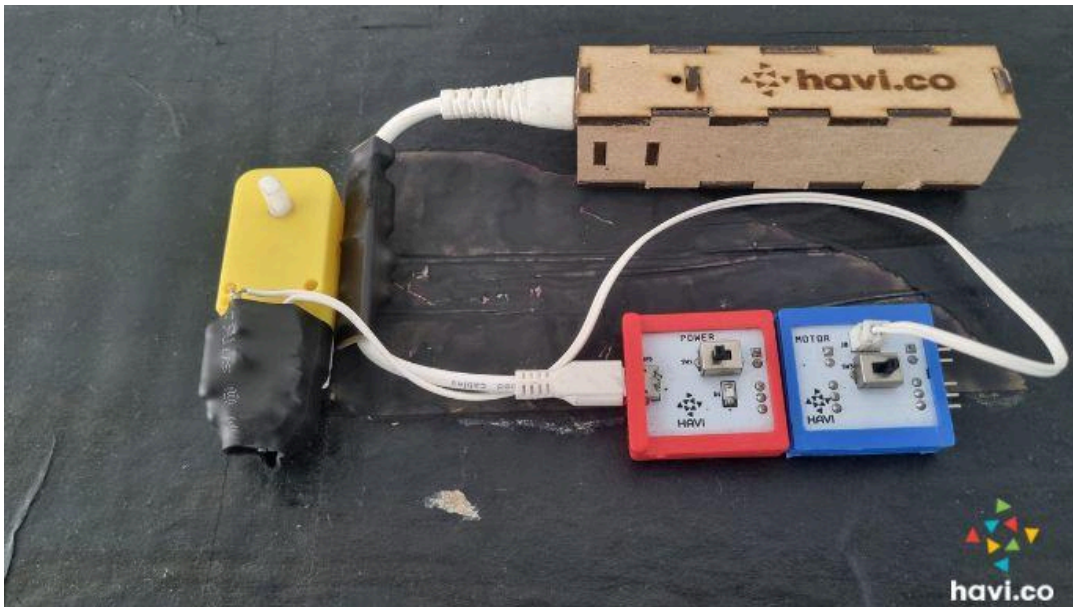

**Step 10** — As you insert the motor shaft into the wheel's shaft slot while making a car, same way insert the shaft into the slot, through the box. With this, your planet disc setup will be hanging inside the box.



**Step 11** — Now, let's make the sun. You can use one or two LED elements to power up 4 or 8 LEDs respectively. Make the circuit and tie the LED cables and USB cable tightly to keep the LEDs pointing upward. We are going to cover the LEDs with a bulb head. And to support that we can use a box and a tripod. You can arrange the things yourself and the final setup should be as shown in the photo. And the bulb head should reach within the planets. See the photos.

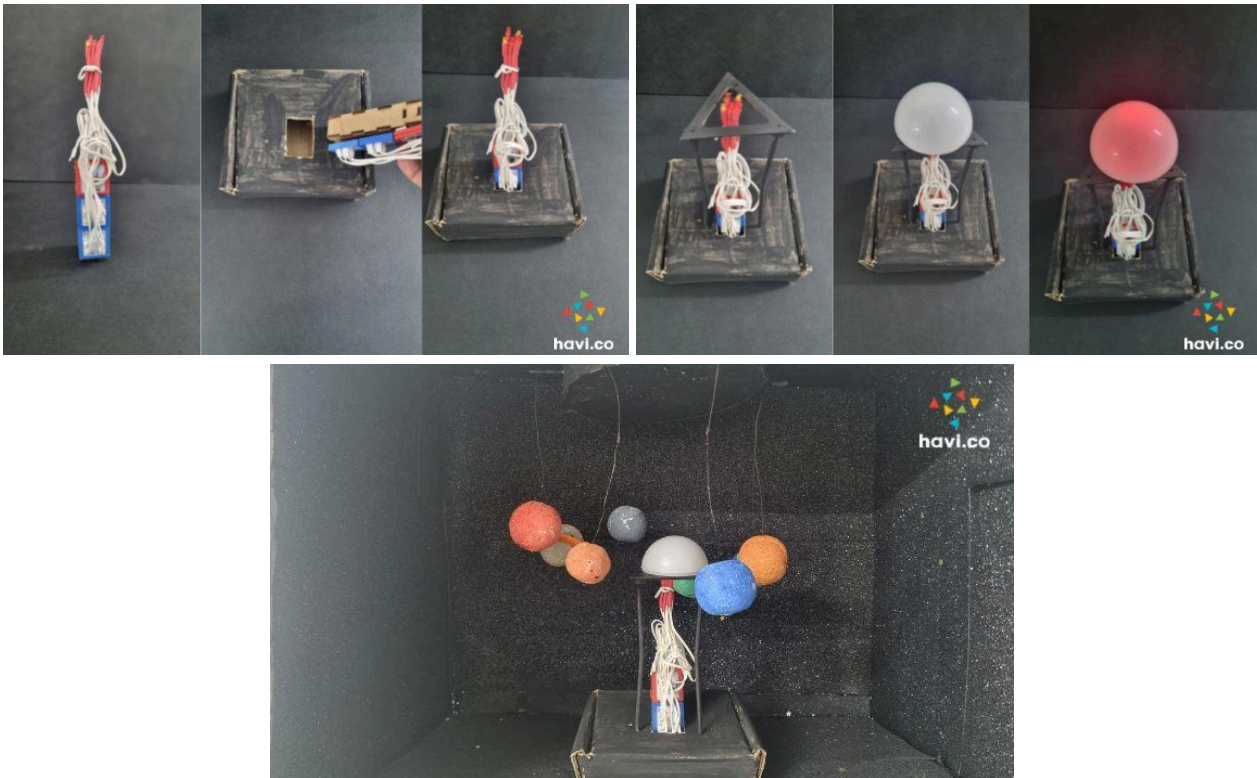

**Play time** : You are done with the setup and it's time to execute and play. First turn on your sun (Power element switch) and then turn on the planet disc. The motor shaft rotates. It pushes the wheel which moves the disc and the disc makes the planets orbit the sun. So much fun! Now it's your time to create. Do it yourself or make a team with your friends, siblings or parents to make this project. Divide the work. Make it beautiful and actual. Share the output with us. If you are publishing on social media, tag us on @MadeByHavi on all the channels.

Chapter 12

# DIY Conveyor Belt with sensor using Havi Elements

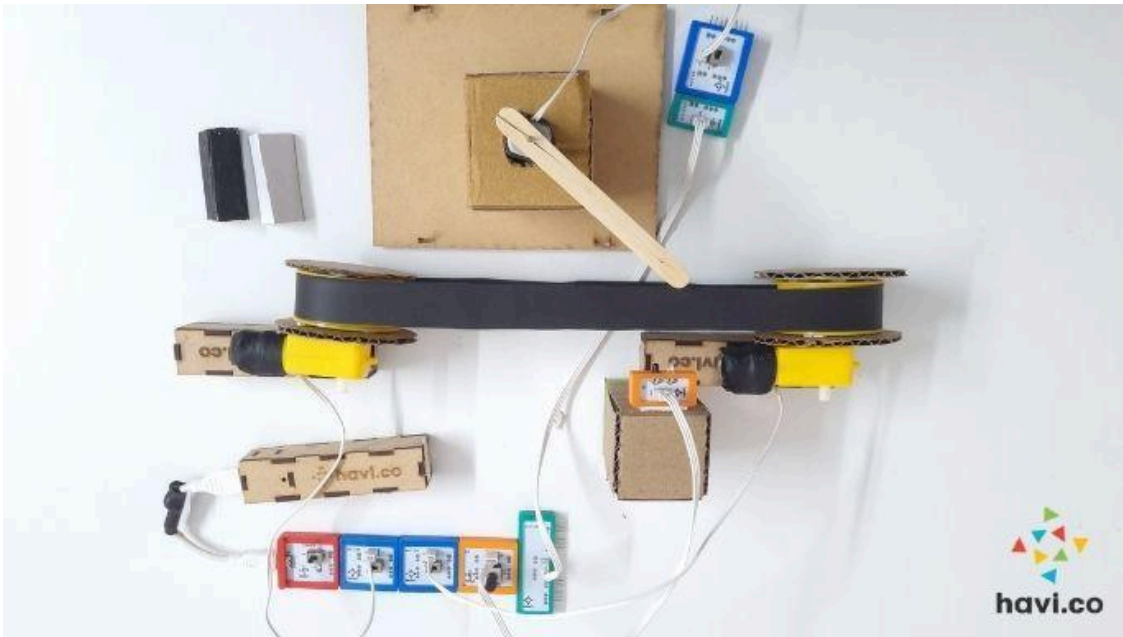

Have you ever thought how factories would have been producing products like cars, phones, and havi.co’s toys?

They use a more than 100-year-old but still useful (after several iterations) mechanism called a conveyor belt.

**What’s a conveyor belt?**

Actually, it’s a transport system for objects. When objects are supposed to be transferred from one place to another within a limited distance, a belt is used for that. The belt can be made out of rubber, plastic, or metal.

The escalator that we see and use at malls and airports are also conveyor belts. And yes yes, the luggage belts too, at airports.

**How to make a DIY conveyor belt model?**

The conveyor belt can be made in 2 different versions.

1. A regular conveyor belt
2. A conveyor belt with a sensor. In this, the sensor will let only black objects pass and white will be taken out.

In this post, we will make both of them. First will make a regular conveyor belt (Step 1 to 7). And then will extend that to a sensor-based smart conveyor belt. (Step 8 onwards)

**Things you need**

Elements	Accessories	Craft material
Power Motor - 2	Power bank with USB Cable Wheel - 2 Geared motor - 2	Double sided tape Card board Double sided tape Tyre tube

## The making

**Step 1** — Remove the wheel grip. We need only the yellow ring for the project but keep the grip safe. Need to cover the wheel back with grip after the project.



**Step 2** — Make 4 discs out of cardboard. The diameter of the cardboard disc should be around 1.5 cm more than the wheel rings, hence at least 7 CM. In two of the discs, Make a hole of adequate size, so that the wheel shafts pass through it without friction and brushing. We need to stick the discs on both sides of the ring using DST. Check the photos for reference.

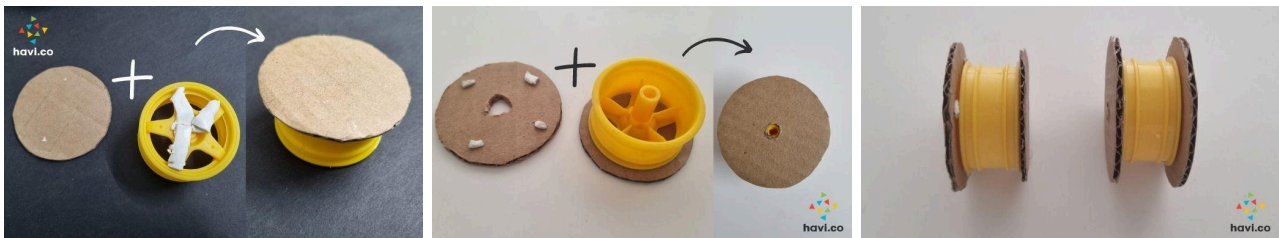

**Step 3** — Cut a piece of a band out of the tube. We have cut the sleeve tube for this purpose. You can use nylon too. The piece needs to be 2 cm in width. It should fit well between the grooves of wheel rings. Use instant adhesive to join the ends of the ribbon and create a ring out of it. This is your belt.



**Step 4** — Snap the ring setup and the geared motor. Use a box or something else which is stronger and is around 2 cm in height. We have used power banks. If you are creating with havi's kits at schools or have friends around having their Havi's robotic toys, you too can use power banks as base. Stick the motors with your base. Make sure the discs are not brushing with the base, motor, or surface. They should rotate freely. Put some pieces of DST on the bottom of your base so that it sticks well with the surface.



**Step 5** — Pass the belt through both rings, so that it remains within the grooves of the rings. Discs are additional support so that the belt does not come out while in motion.

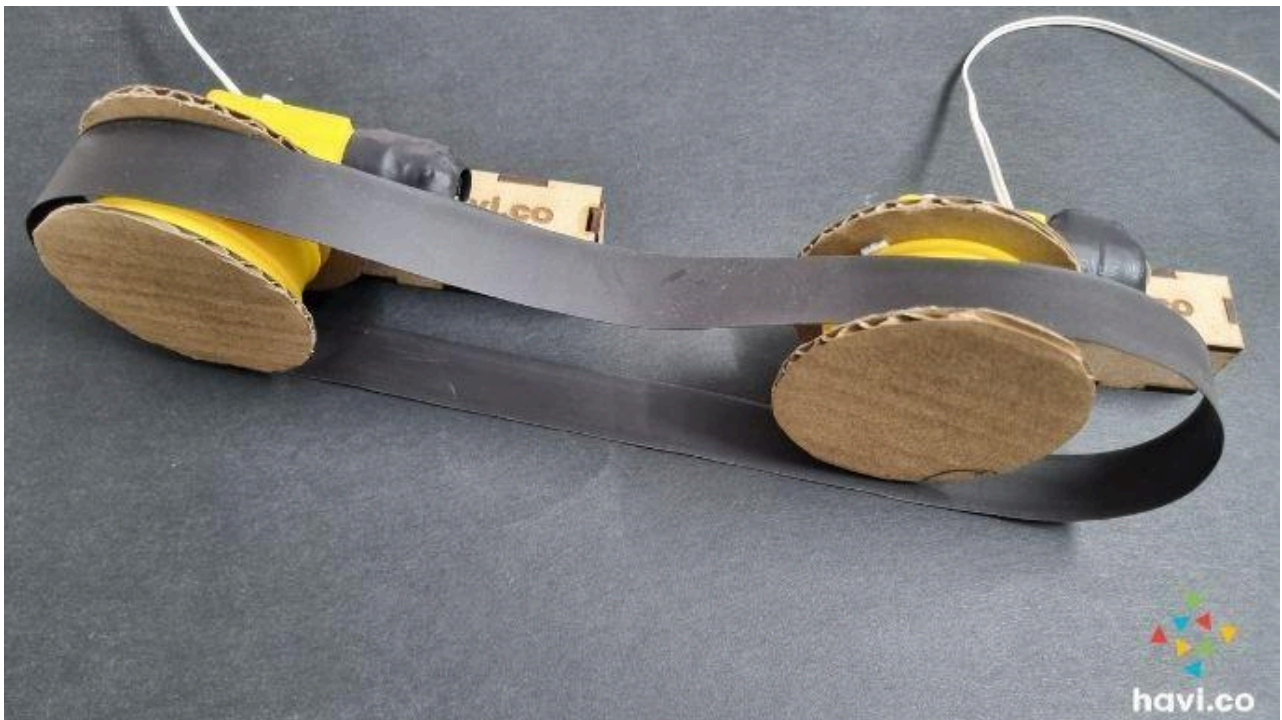

**Step 6** — Keep both motors at an adequate distance so that the belt remains tighter. Stick the setup with the surface.

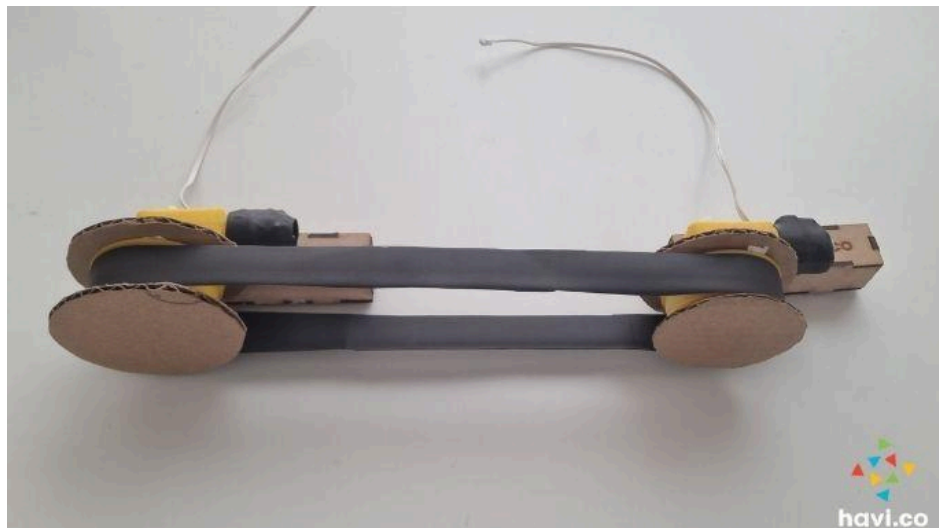

**Step 7** — Snap the Power-Motor-Motor circuit and connect with a powerbank. Connect geared motors with motor elements. Your conveyor belt is ready. Switch the power element on and it would start. Troubleshooting tips Both motors should be rotating in the same direction. The belt should be adequately stretched. If it is loose, the belt will not move onward and may come out of the wheels. If it is way too tight, DST won't be able to hold the bond. The discs should be of adequate size to prevent the belt from coming out while moving.

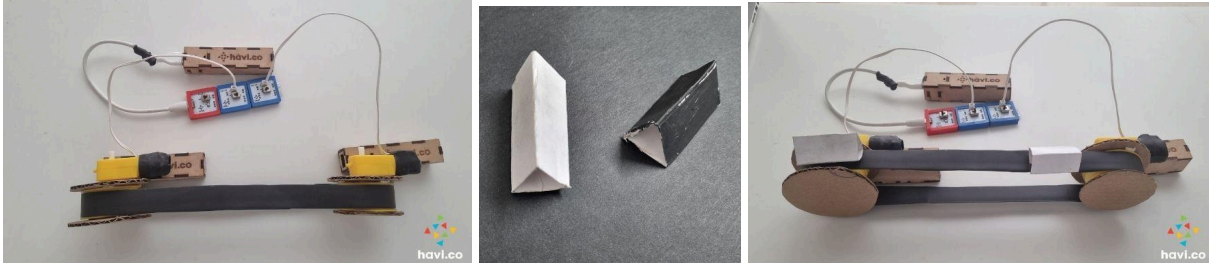

**Sensor based DIY conveyor belt project**

And from here, we convert this into a smart, sensor based conveyor belt. This conveyor belt will distinguish between white and black objects and will let only black objects pass on the belt.

**Additional material required for a smart, sensor based DIY conveyor belt project**

Havi Elements: IR Element Motor Element Extend Element

Accessories: Gearless motor

Craft material: Smaller boxes (2) or cardboard to make them. Rubber bands (If we are making boxes ourselves) Icecream stick

**Step 8** — We need a couple of boxes as motor holder and IR stand. Pierce the top of the motor holder box and make a hole so that the gearless motor passes through it and stays firm inside. Pierce your ice cream stick and insert the shaft of the gearless motor into the hole. Place the IR stand at the side of your circuit and the motor holder at the opposite side.

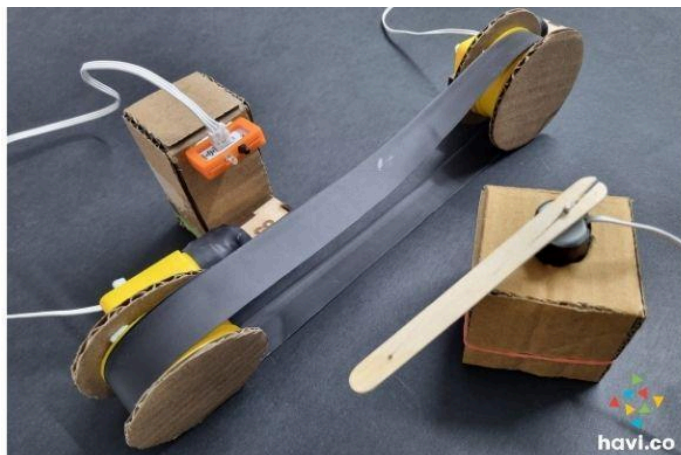
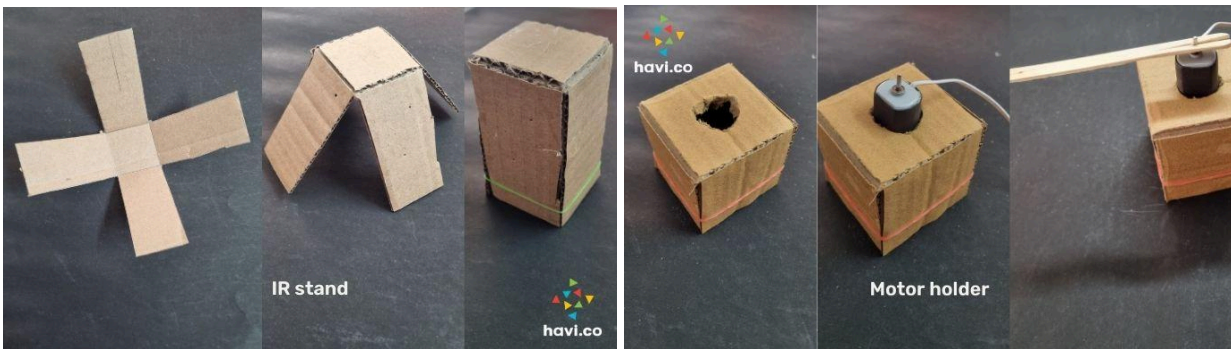

**Step 9** — Adjust the heights of the IR stand and motor holder if required. Both of them should stay around half a centimeter above the belt. Snap the IR, Extend and motor elements with your

circuit. Checkout the photo. The cable of the extend element is passed under the belt. Sticked to the surface using smaller pieces of DST, to avoid belt brushing with that cable. Tune the potentiometer and your smart, sensor based conveyor belt is ready.

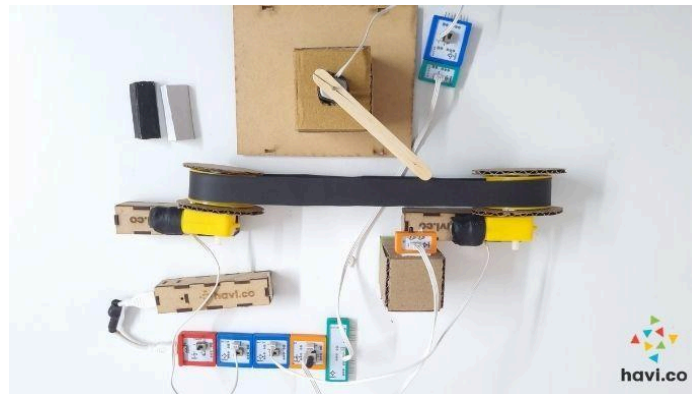

### How does it work?

Try placing black and white objects separately. The gearless motor is under control of the IR element. So when the IR detects an object, the gearless motor will turn on and an icecream stick connected with it will wipe the object away. As the object goes off, the gearless motor will stop. When you are placing black object, the IR element won't be able to detect it as an object so it will pass through the belt. WHY?. When you are placing a white object the IR element will detect it as an object and as mentioned in point 2 above, the motor will take it away. BTW you can do the opposite too. Take the black objects away and keep white (In Fact any other color) objects on the belt. How? Dot it and let us know.

## Chapter 13

# How to make automatic hand dryer at home

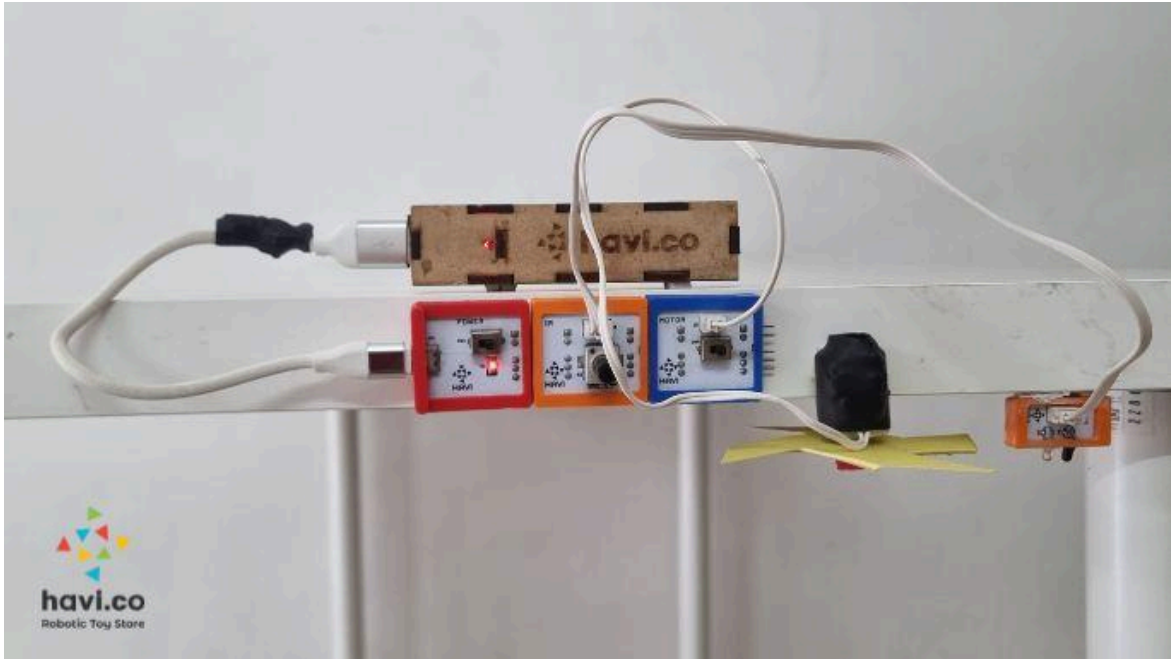

You must have been a traveling freak and explored many places in India & World. You might have seen the machines that automatically dries your hands. Yes, the machines that we saw in the washrooms of restaurants and hotels to dry your hands with the flow of air. The machines are automatic as well. Place your hand below, and it will blow the air to dry your hand.

Let's prepare a mini project on an automatic hand dryer using Havi Elements. You can find the elements and accessories from Havi's DIY Robotics Starter Kit.

### Things you need

Elements	Accessories	Craft material
Power Motor IR	Power bank with USB Cable Gearless motor 3-pin cable	Double sided tape Craft paper Scissor Scale/Pencil Fevicol Pin

### The making

**Step 1** — Measure a piece of craft paper with a scale of 7 cm and cut it into a square.

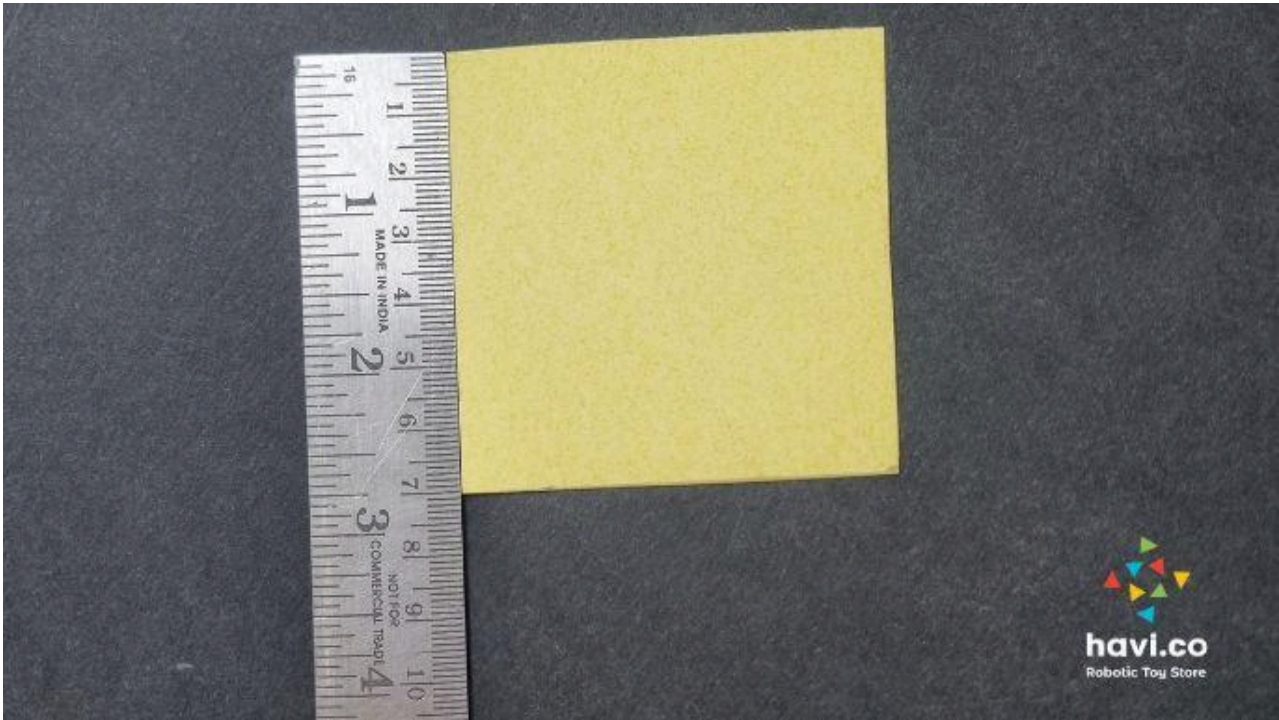

**Step 2** — Draw 2 diagonals from the edges of the square, and mark 3 cm distance from all the sides.

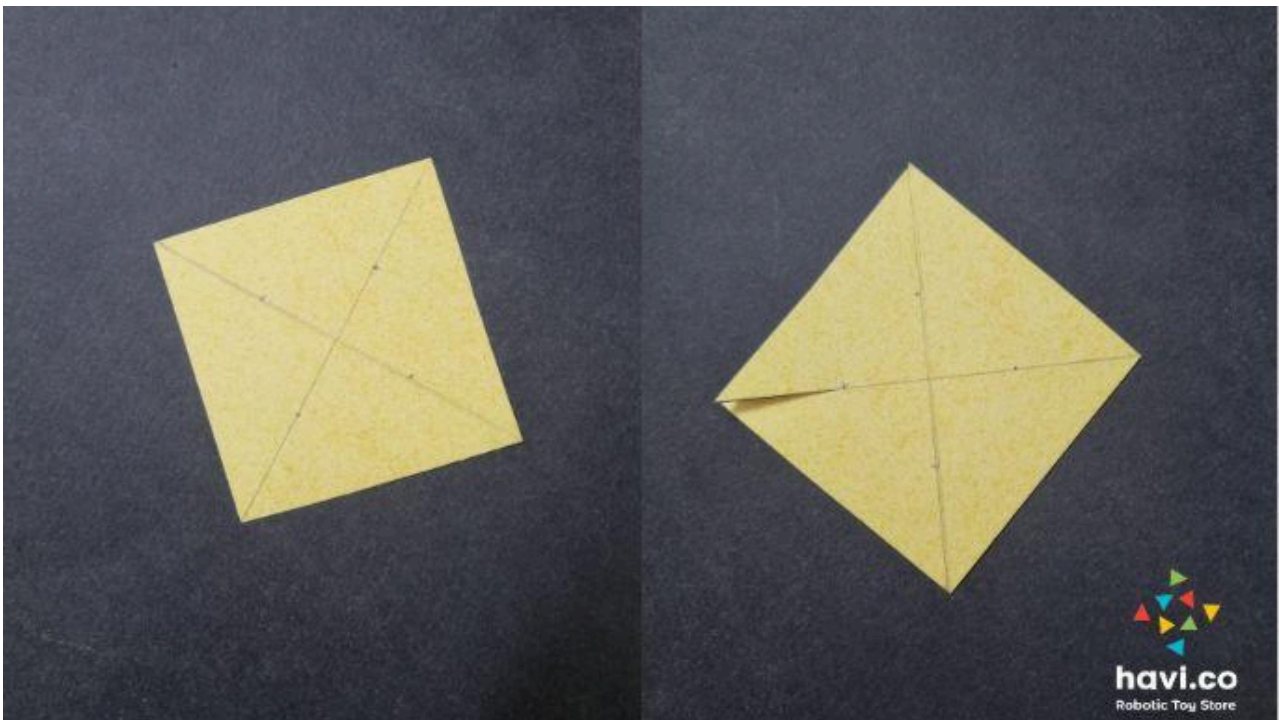

**Step 3** — Cut the paper from diagonal lines to the 3 cm mark on all sides.

**Step 4** — Fold the cut paper inwards as shown.

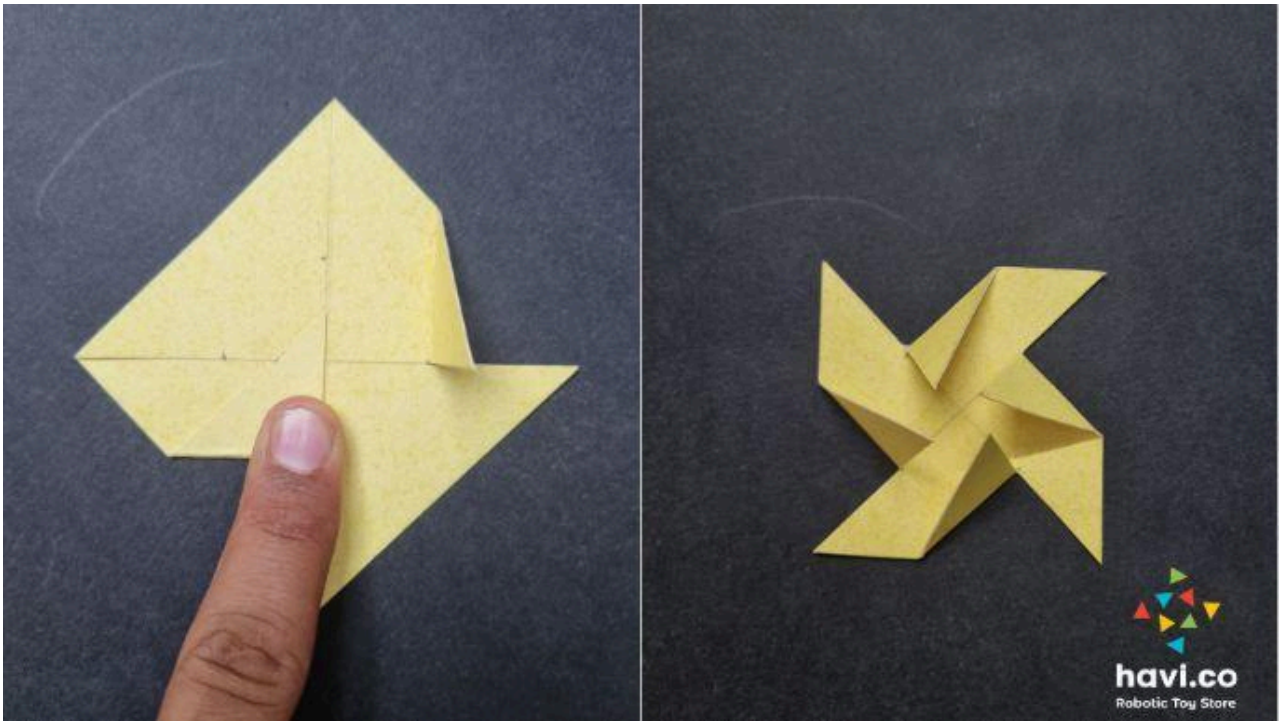

**Step 5** — Put a drop of glue on the edges of folded paper and stick it inwards. The dryer fan is ready.

**Step 6** — In the center, make a hole using a pin.

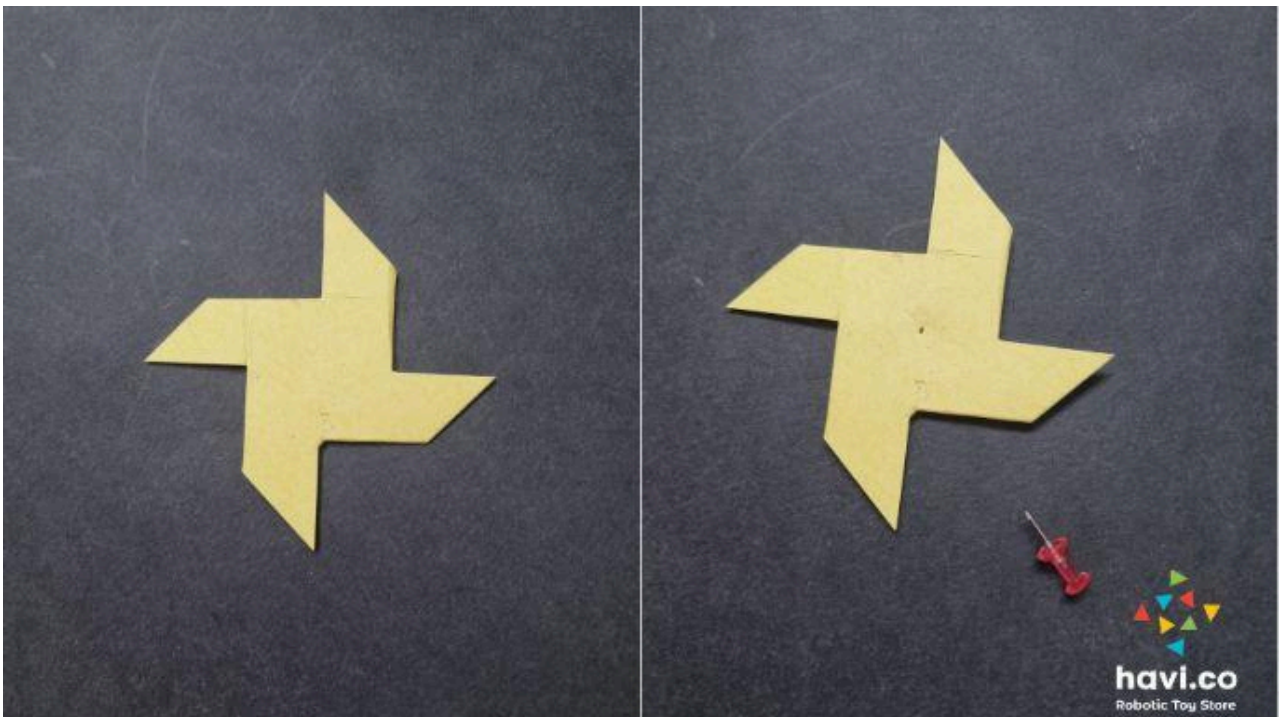

**Step 7** — Make the circuit using Havi Elements as below. Connect the gearless motor with Motor Element. Connect the powerbank.

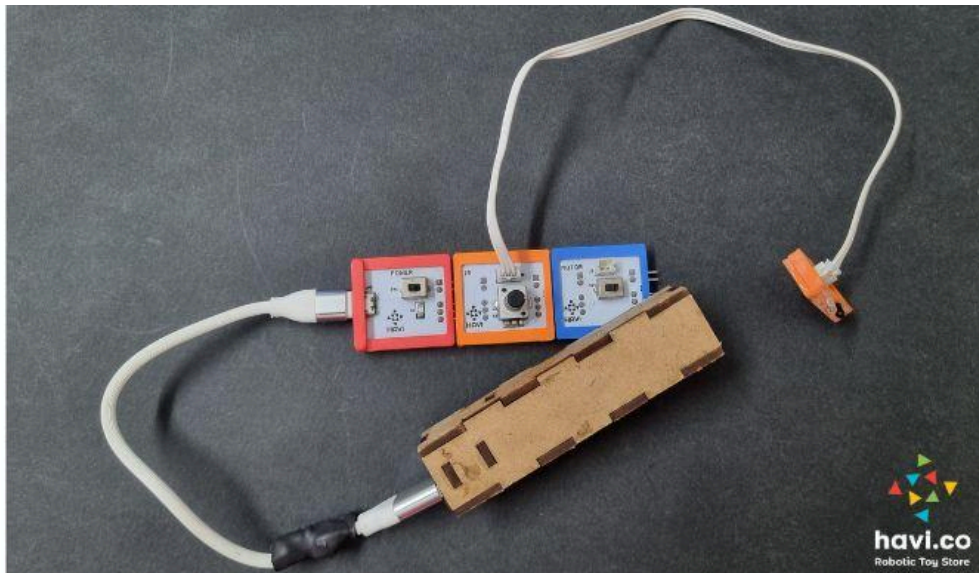

**Step 8** — Stick the circuit over the power bank using double-sided tape. Stick the powerbank and gearless motor using double-sided tape and prepare a setup. Now, fix the dryer fan with the shaft of the gearless motor. Keep the IR LED near the dryer fan. Your DIY hair dryer is ready.

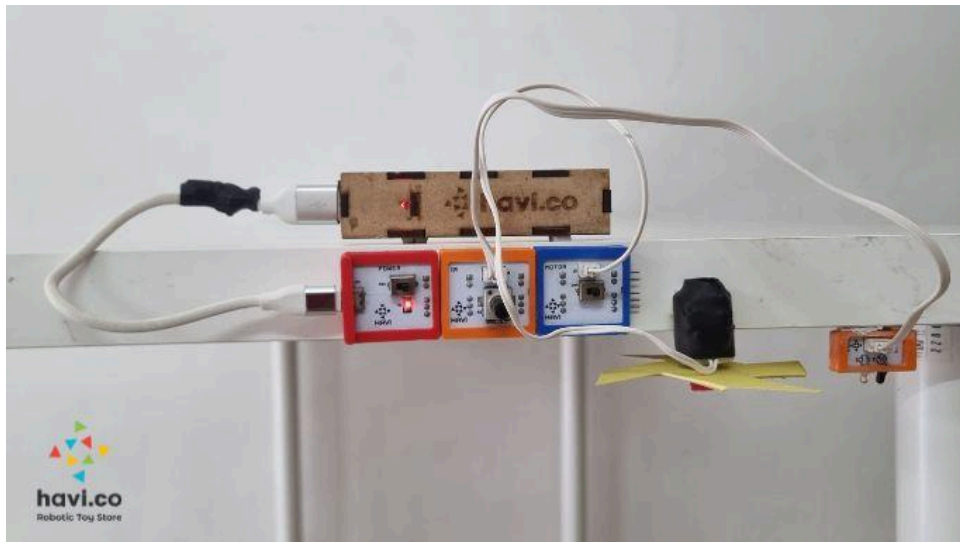

### How does it work?

The IR Element(IR sensor) used to detect the object nearby. When the IR sensor detects our hands, it will send a YES signal to the next Element, means Motor Element. As soon as Motor Element receives a YES signal, the attached gearless motor rotates, and hence the hand dryer fan will rotate, too. Know more on how IR sensor works. The challenge for you! We have executed the project more simply. Can you make an attractive outer model for your hand dryer? Here comes a challenge for you. Make the outer design for the DIY hand dryer and share your STEAM project model with us.

## Chapter 14

# Reverse Car Parking Sensor Project using Havi Elements

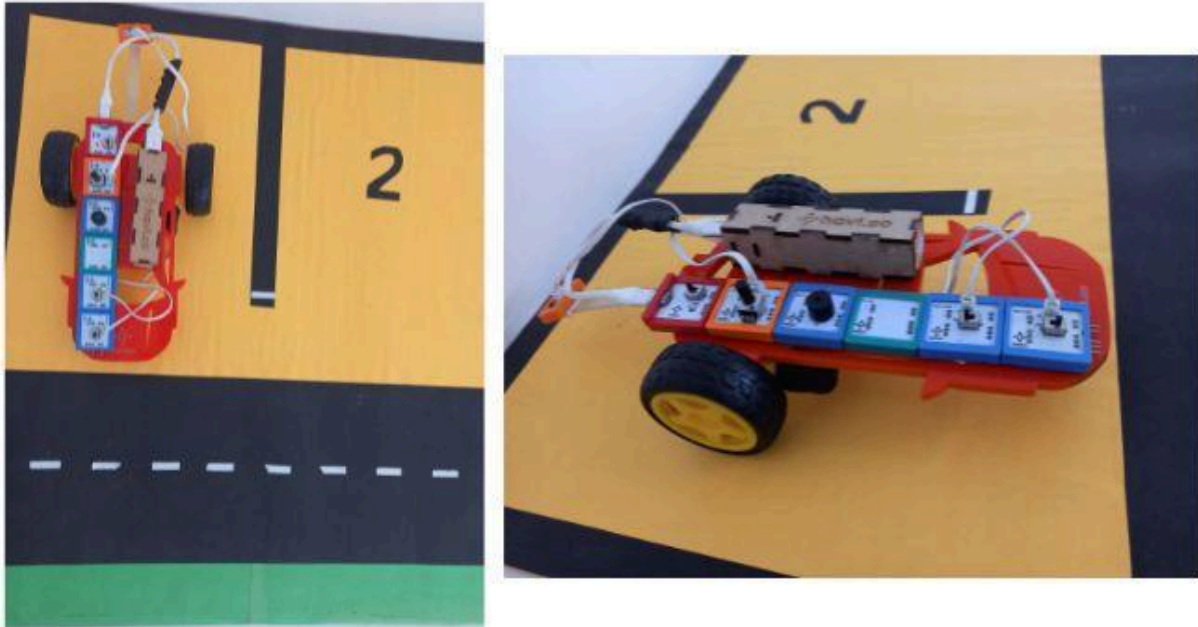

Aane de... Aane de.... Aane de.....

You must have seen as well as been in this situation. Someone is driving the car in reverse and Dadaji or Buaji is guiding them, especially while parking a car in reverse.

But you might have also observed one or many of the following features in a car.

- A car that beeps or plays a tune while driving in reverse to keep the driver alert.
- A car that beeps when an obstacle, like a wall, is approaching.
- The rear of the car displayed on the media screen, along with drawings showing the car's coverage, allowing you to see if something is in the car's path.
- A car that stops by itself if it is about to approach a wall or a pole.

Cars have become smarter and smarter with these advanced features, reducing the need for someone to guide you with "Aane de...." and increasing the overall safety of the vehicle and its occupants.

Now, let's build a working model of a reverse car parking sensor project using Havi elements and also understand how this system works.

What is reverse parking sensor

Reverse car parking sensors are tiny electronic devices that can be placed at the rear bumper of a car. They measure the distance between the rear bumper and the object in front of it.

If the minimum safety distance is breached, the sensor activates safety measures, which can be a beep, a tune, or a brake, in the case of smart cars.

Which sensor is used in reverse car parking?

IR sensor, Ultrasonic sensors, motion detectors and cameras can be used as reverse car parking sensors. Each of them do have different features and purposes.

We will use IR sensors to build our reverse car parking sensor project.

What is the objective of a car parking sensor?

The top most objective of a car parking sensor is to prevent the damage or loss of vehicle, properties and lives of humans.

### Things you need

Elements	Accessories	Craft material
Power Motor IR Flip Buzzer	Power bank with USB Cable Car plate Geared motor - 2 Wheel - 2 Roller 3-pin cable	Double sided tape Ice cream stick

### The making

**Step 1 Building a car** — Let's begin the creation process by building the car first. You can refer to the instructions on "How to make a DIY robotic car using Havi elements" to learn how to construct the car structure.

#### Step 2 —

**Version 1: Alarm system** First, let's create a basic reverse parking alarm system that activates the alarm when the car comes closer to a wall or any other object.

Prepare the reverse car parking sensor circuit as follows:

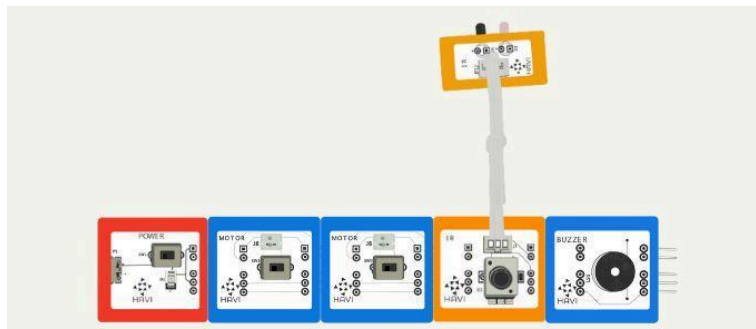

Attach a piece of double-sided tape (DST) at the bottom rear side of the car plate.

- Stick one edge of the ice cream stick on that piece of DST.
- Connect the circuit to a power bank.
- Place and attach the circuit and power bank over the car plate using DST.
- Connect the geared motors with the motor elements.
- Connect the IR LED and IR controller using a 3-pin cable.
- Stick the IR LED on the other edge of the ice cream stick.

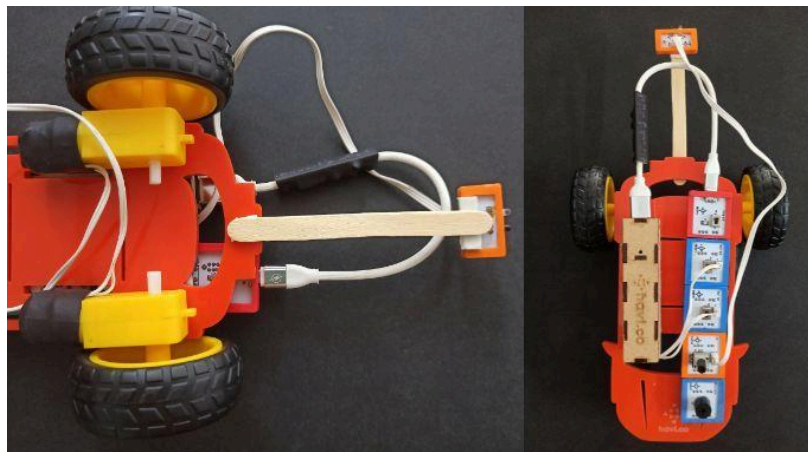

Next, adjust the sensitivity of the IR sensor using the potentiometer. The sensor should detect the wall from a maximum distance, so set it to maximum sensitivity. Adjust the motor switches so that both motors rotate in the backward direction. Now, our reverse car parking sensor project with an alarm is ready. Turn the power ON, and the car will start moving backward. As the car approaches the wall, the buzzer will sound, serving as an alarm to alert the driver about the approaching obstacle. However, in our case, the car will remain uncontrolled and may hit the wall.

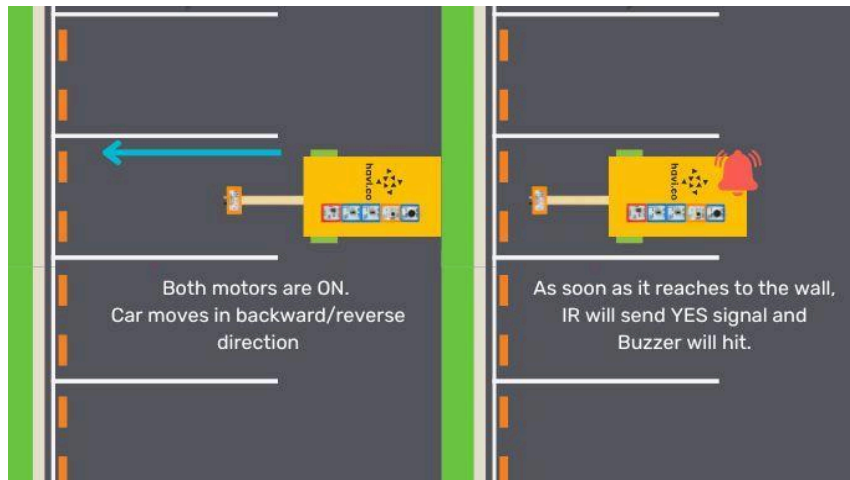

**Version 2: Smart reverse parking sensor** What if we want to create a smart car that stops automatically when approaching a wall? Then we can call it a robot car as well! Let's now prepare a smart reverse parking sensor project in which the car will stop by itself and activate the buzzer. However, if you want to eliminate the buzzer, you can do so. Modify the circuit as shown here.

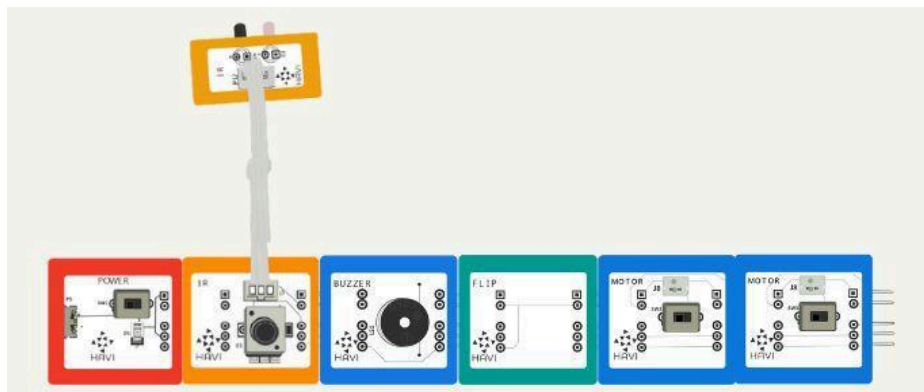

Turn the power ON, and the car will start moving backward. As the car approaches the wall, the buzzer will sound, and the motors will stop rotating.

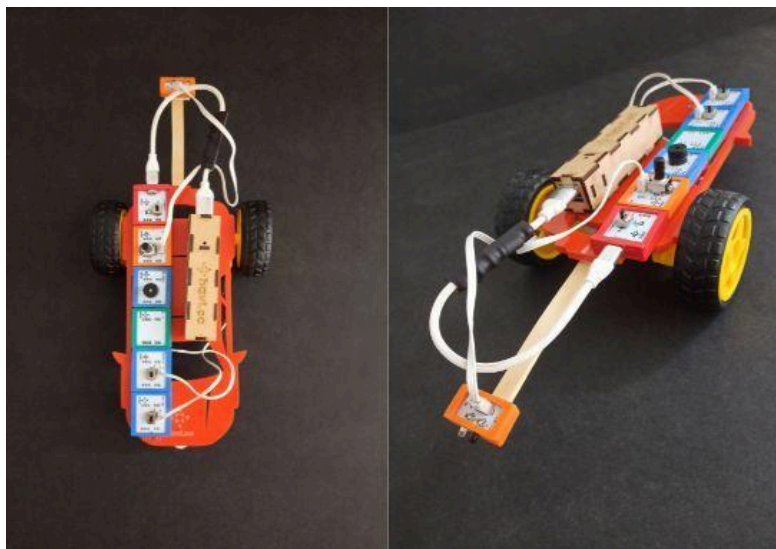

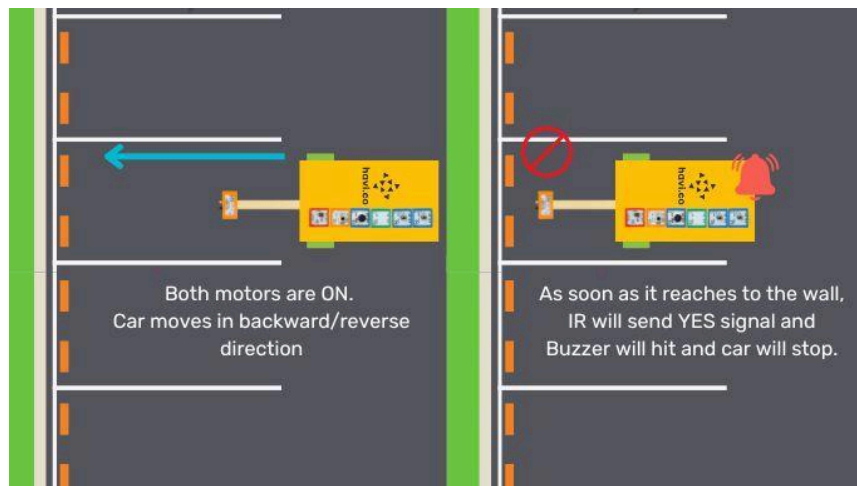

**Version 1: The alarm**

In the first case, the IR sensor will detect an object and send a “Yes” signal to the buzzer. Buzzer will turn on and will make the sound. However motors are not under control of the IR element hence will continue working normally.

**Version 2: The smart stop**

In the second case, We bring motors under the control of IR+Flip and the buzzer under control of IR.

When there is no object in the way, the IR sensor will release a "No" signal to the buzzer. The buzzer will remain off and forward the "No" signal further to Flip. Flip will receive the "No" signal, flip it to the opposite ("Yes"), and pass it to the motors. As a result, the motors will remain on.

However, when the IR element detects an obstacle, it will send a "Yes" signal to the buzzer. The buzzer will turn on and pass the signal to Flip. Flip will invert the signal to "No" and transmit it to the motor elements. This will make the motor elements stop, causing the car to come to a halt.

That's a smart reverse mechanism using an IR sensor.

**What are the benefits of reverse parking sensors?**

The alarm mechanism alerts the driver for the upcoming obstacle while the smart reverse sensor delivers much more. That prevents accidents to happen as it stops the car by itself.

School students can prepare some impressive craftwork and present this project in their school science fairs. Check out the example below.

What else can we do to make reverse car driving safer? What other car safety projects can you make using Havi elements? What else can you do with this same circuit?

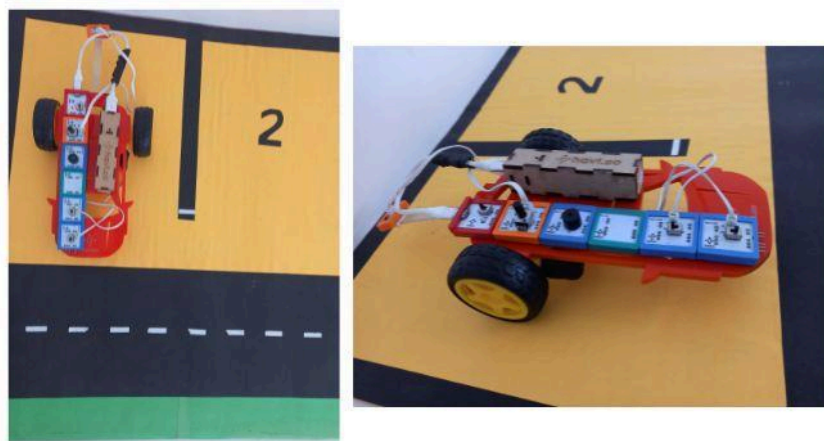

Think, play, and learn....till we come back with a new post.

## Chapter 15

# How to make automatic street light project



Majunsha went to Oslo of Norway, which was the first city to install citywide automatic street lights. She was surrounded by family and friends to discuss not just her travel experiences but also to know more about smart street lights, Light sensors, LDRs, and IoT.

Automatic street light introduction

What is a smart street light? Little Cherry asked Manjusha.

When we are adding the word smart to anything, at least we have some sense of automation, computers and technology in general.

Same is the case with automatic street lights. An automatic street light is the one which adapts to the surroundings be it environment or vehicle movement. According to the surroundings it may turn on, go off, dim down or brighten up.

Take for example a street light that turns on by itself at night or a street light that dims down when there are no people or vehicles on the street. These are automatic or smart street lights.

Which sensor is used in smart street light?

Multiple sensors can be used to make a smart street light project. Let's know about a few.

LDR: Light Dependent Resistor, which helps detect the presence of light. Read How LDR light sensor works to know more.

IR Sensor: Infrared Sensor, which helps detect an object. Read How IR sensor works to know more.

Ultrasonic sensors: These sensors too, can be used to detect an object.

Motion sensor: To detect the movement.

In this blog, we are going to make an automatic street light using LDR (The light element)

## Things you need

Elements	Accessories	Craft material
Power Light Flip LED	Power bank with USB Cable LED Cables - 4	Double sided tape Paper straws Construction/card papers Colors Cardboard

You can use any of the following kits to make automatic street light project.

1) Havi Elements - DIY Smart Lighting Kit. You will not have to create your own craft. You will get craft ready in the box. Assemble the papers and create your streetlight scene. And then make elements circuits. Suitable for beginners.

2) Havi Elements - DIY Robotics Starter Kit. You will make your craft yourself. Suitable for more serious creators, school projects, longer projects.

Once we have all of these, we can start making the circuit first.

**Step 1** — Make following circuit Follow the steps provided in the images here and in the video at last to make the setup of your smart street light project.

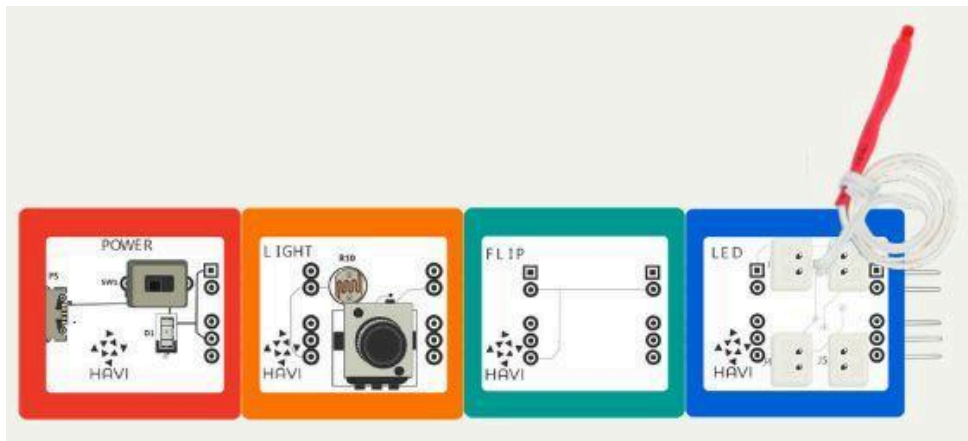

### Step 2

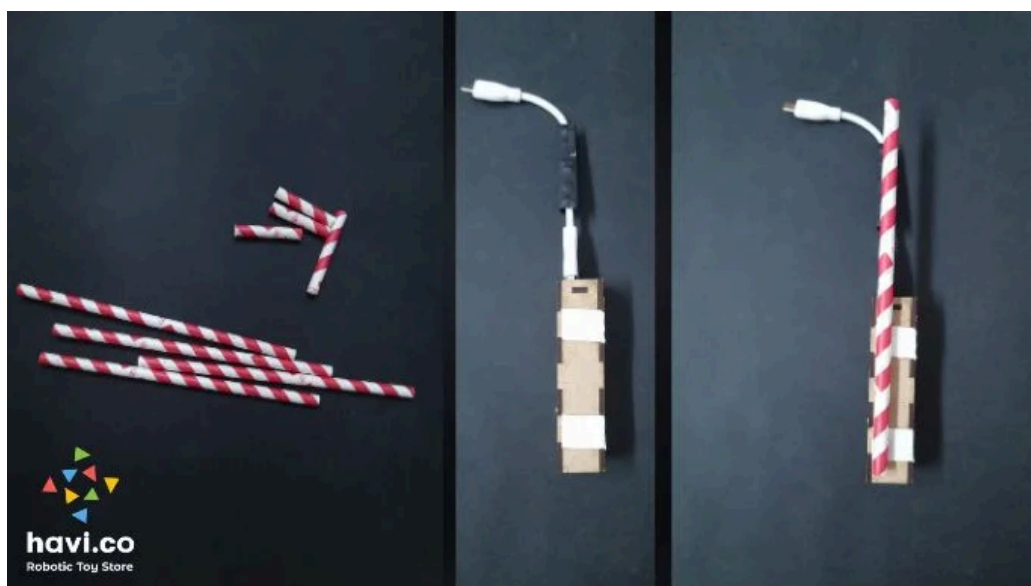

### Step 3

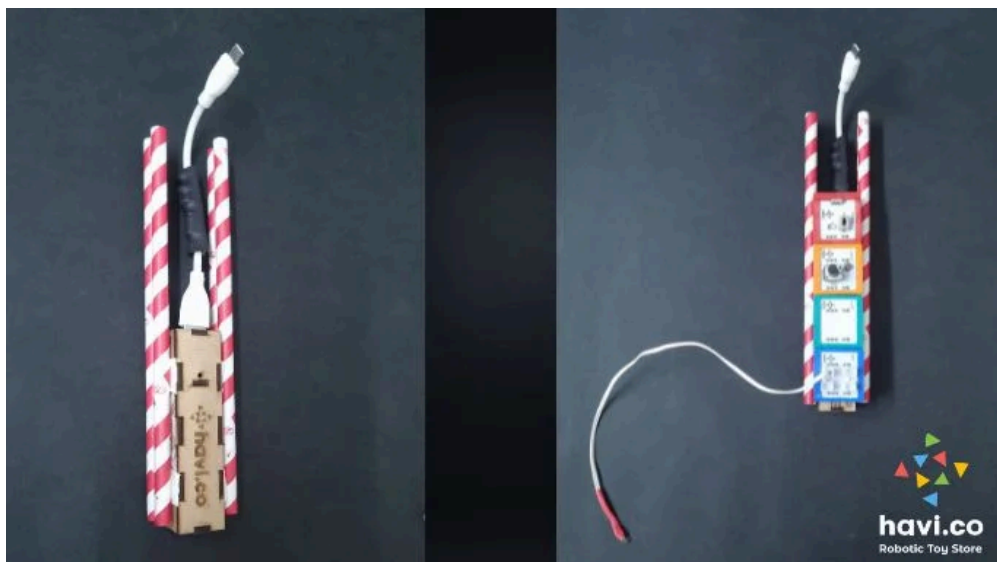

### Step 4

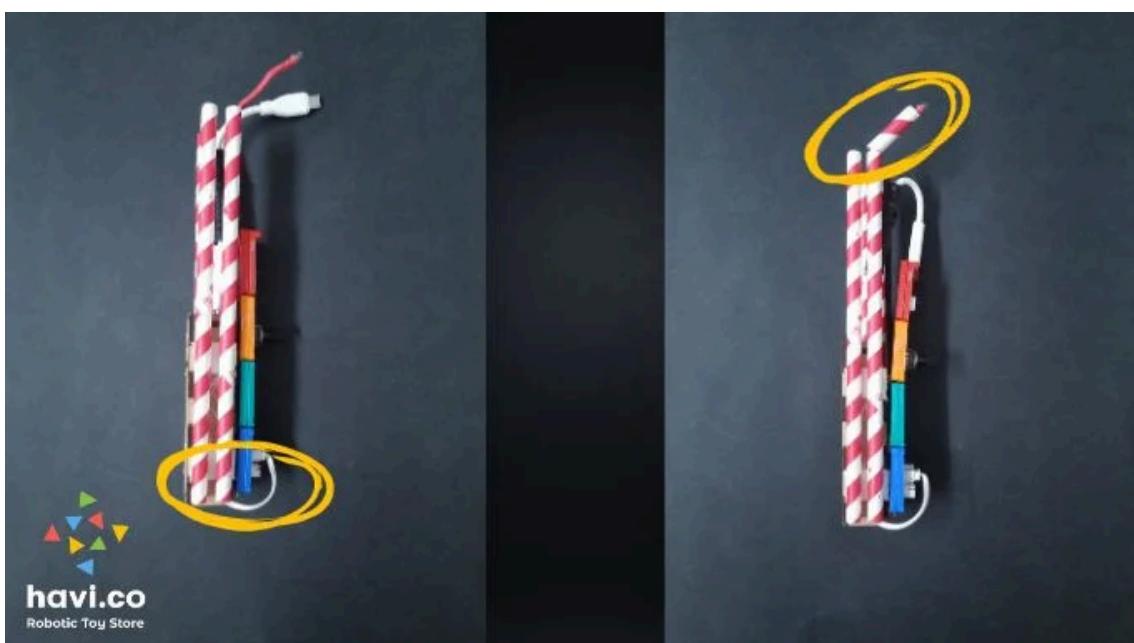

### Step 5



Adjust the potentiometer of the light element in the middle so that the LDR can detect the adequate light. Turn the surrounding lights on and off to check your circuit. LEDs should glow up in the dark and will go off in the presence of light. So you have successfully made the electronics and sensor part of your automatic street light project.

### **The model of automatic street light**

As we are done with the circuit, let's make a beautiful street view to use our smart lights. Use your creativity along with craft material, team up with family or friends if required and make a street setup that you like. Can make roads, houses, trees and greens. We have used the street view templates provided in the havi's DIY Smart Lighting Kit. You can make your own if using DIY Robotics Starter Kit. How does an automatic street light work? See, we have LDR in the light element. That detects the presence of light. In the presence of light, it will pass an appropriate signal to the next element which is flip. Now Flip has a characteristic as you know that it flips the input provided by the sensor. So the Light element has said YES, Flip will convert that to NO and will pass to the LED element. The LED element will understand that I am not supposed to work. When there is darkness, the Light element will say NO to flip, which the flip will pass to the LED element after converting to YES. So the LED element will believe that I should work and will lighten the LEDs! And we have lights, the smart street lights! Advantages of automatic street light (And disadvantages as well)

### **Following are the key advantages of using smart street light.**

- Most important would be the savings of energy. The automatic street light can turn on and off and can go dim by itself. That saves energy. Hence environment and money.
- Administration doesn't set up street lights at not-so-busy roads sometimes to save the cost. Installing automatic street light reduces the running costs which motivates to setup street lights on these roads. That improves public safety and convenience.
- Lower risk of overheating of the bulbs, LEDs and circuits as they get breaks. This increases the lifetime of the street light.
- Not too much human intervention is required to operate the street lights.
- Since the lights would be controlled by the sensors, people will get the street light earlier and for more hours during the winter and later and for less hours during summer. Saves cost of consumption and improves public convenience.

**While there are several benefits of smart street light there are few disadvantages as well. Let's look at those**

- Cost of such sensor based street lights would be higher.
- High cost of the units increases the chances of theft and fraud.
- Sensors are required to be protected from dust and other environmental conditions in order to work properly. It may need frequent cleaning too.

What is the future scope of automatic street lights?

As far as our project is concerned, we can Add one IR element and one LED element to the circuit and make it dependent on the vehicle movement. Lights to turn on or brightup while there are people, vehicles and other objects on the road.

At the automatic street light side, further improvements will happen to reduce the cost of production of these kinds of lights. Once done, this can be implemented at scale and can save further costs. Further on with implementation of IoT (Internet of Things) the street lights can be “connected street lights” and will start serving more facilities to the citizens.

Hope everything is clear. But now, this blog is not just to be read. Make your own automatic street light, at home with family and friends and at school as well.

Do share your smart street light photo and video with us.

## Chapter 16

# Make a smart street light project using IR sensor



What is an automatic street light? How does a smart street light work? What are the advantages and disadvantages of automatic street lights? We have discussed all of them in detail in this post: How to make automatic street light project – DIY smart street light model.

So in this blog post we will focus on making an automatic street light project using IR sensor.

Introduction of Automatic street light project using IR sensor

Automatic street light using Light sensor (LDR): You can make a smart street light that goes on and off based on the availability of light in the environment. It will turn on in case of darkness and will go off in daylight.

Automatic street light using IR sensor: We can make two features of automatic street light using IR sensor.

1. A street light that goes on and off based on object movement. The object can be a vehicle, a human, or an animal.
2. The street light that goes on and off based on the sunlight. In presence of adequate sunlight, the street light will remain off, and in absence, will turn on.

We will discuss making both of these features here. But the problem is, both of them can't work together in a single circuit.

## Things you need

Elements	Accessories	Craft material
Power IR LED	Power bank with USB Cable LED Cables - 4	Double sided tape Paper straws Construction/card papers Colors Cardboard

You can use any of the following kits to make automatic street light project. 1) Havi – DIY Robotics Starter Kit. 2) Havi - DIY Robotic Car Kit.

You will make your craft yourself.

Once we have all of these, we can start making the circuit first.

### Step 1 Make following circuit — Power + IR + LED

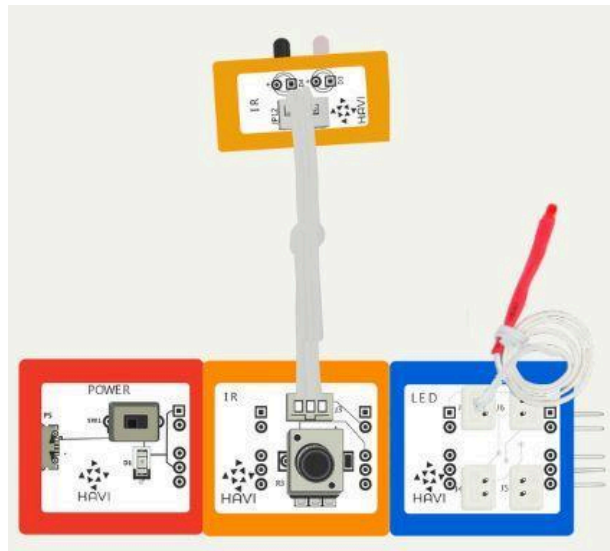

### Step 2

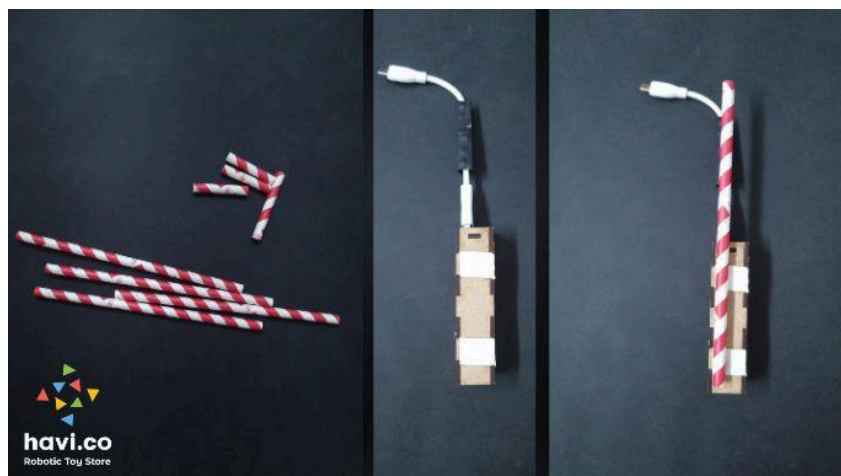

### Step 3

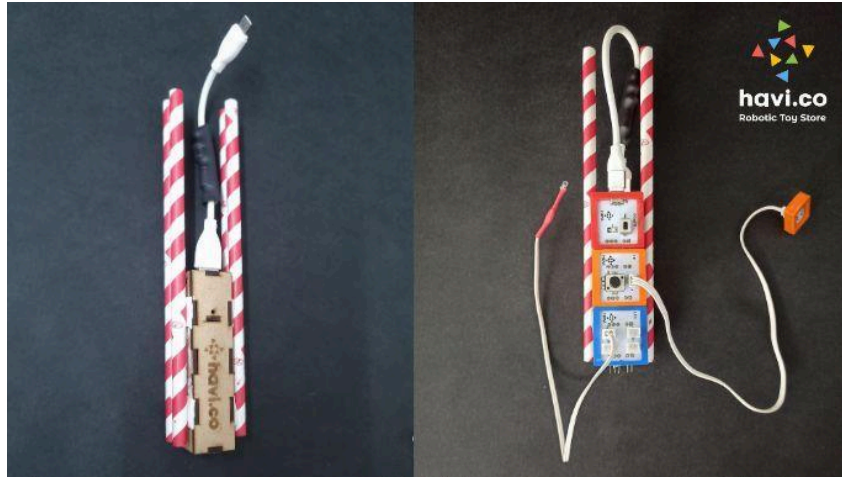

**Step 4**

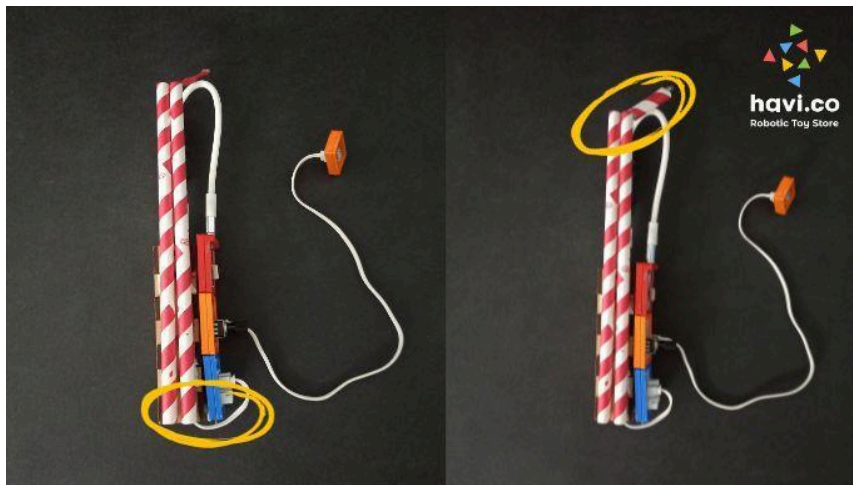

**Step 5** — Adjust the potentiometer of the IR element in the middle so that the sensor can detect the adequate light. Bring an object near to the IR LED and test your circuit. LEDs should glow up in the dark and will go off in the presence of light. So you have successfully made the electronics and sensor part of your smart street light project. Make a platform of height 3 cms using the project paper. Choose length and width according to your project plan. Color it to make it look beautiful. You can draw roads, greens etc. of your own imaginations. Make two a hole in the box, one to pass the cable and another to hold the IR led at the surface.

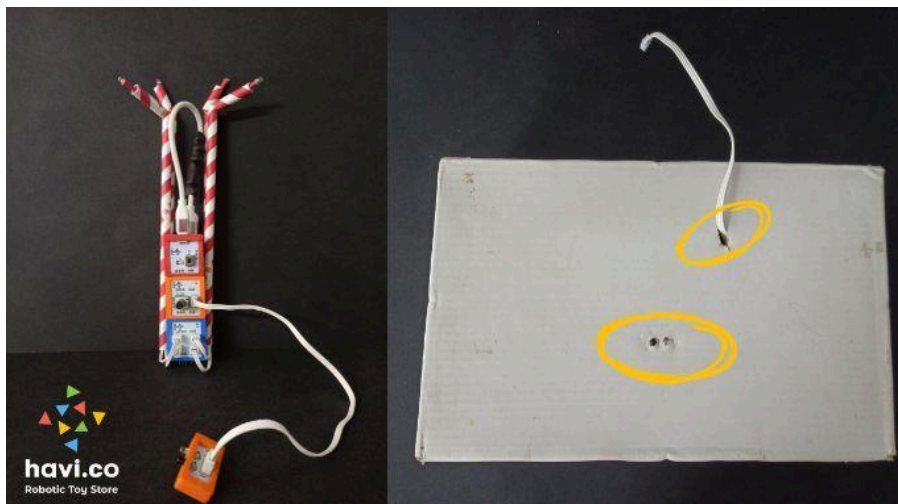

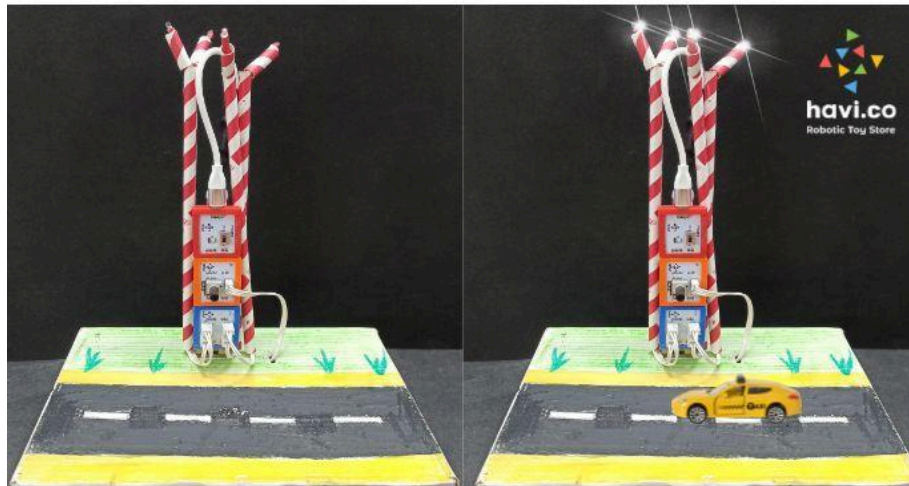

Your IR sensor based smart streetlight project is ready. The streetlight should turn on as a toy vehicle passes on the Sensor LEDs and will turn off when gone.

### How does it work?

The IR sensor will detect a vehicle, or human or animal, passing on the road as object. As the IR detects an object, it will send the signal to the LED element and light will turn on. The LED will turn off after the object goes off. Also sunlight has IR rays, so in presence of the sunlight the LEDs will turn on. If we want to do the reverse, should add Flip Element between IR and LED element. Change the circuit as shown below: Advantages when implemented in the real world. We have discussed about advantages and disadvantage of implementing smart streetlights in our blog of How to make a smart street light using Light sensor. So not discussing them again here. So your tiny invention can solve a huge problem! What else can you do with this same circuit combination? Share your ideas and project photos here.

**Chapter 17**

# Automatic headlight dimmer/dipper project using Havi Elements

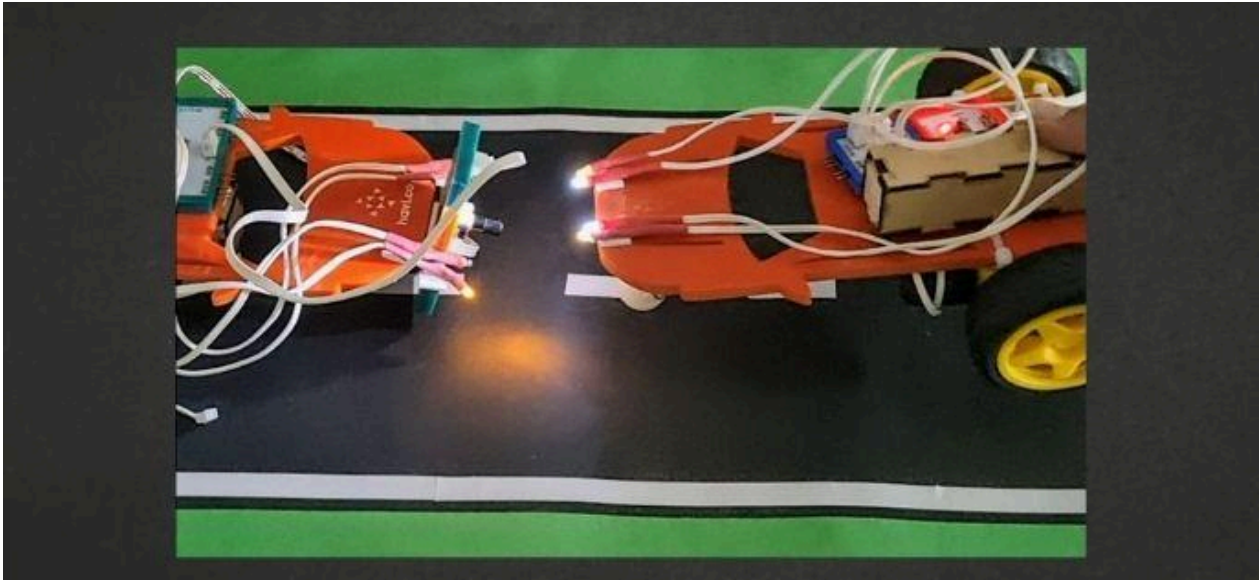

“I avoid driving at night. Headlights, specially the dippers glare from opposite vehicles glares my eyes. Vehicles have dipper lights for clarity over long distances, especially over the highways. But when not used wisely, the same feature causes glare and temporary blindness to the vehicle of oncoming car which ultimately may result in fatal accidents.

Whom to complain? Rather why to complain? Let’s take help of technology.

Yes we can get help of sensors and smart technology to solve this problem. Let’s create a prototype solution for this problem.

We’ll develop an automatic headlight dimmer/dipper project in which the vehicle’s headlights dim by itself when oncoming another vehicle approaches from the opposite side.

We can develop this project using Havi’s Robotic Starter Kit. This can be a winning science and technology project for schools and science fair.

For prototyping, we will create two models of non moving cars: one with regular headlights car and another with smart-sensor based headlight.

We will create two models of cars: one simple car and one automatic headlight dimmer/dipper car. For simplicity of understanding, we will make static cars.

### Things you need

Elements	Accessories	Craft material
Power - 2 Light LED - 3 Flip Extend pair - 2	Car plate - 2 Wheel - 4 Roller - 2 Geared motor - 4 LED Cable - 8 Power bank with USB Cable - 2 3-pin cable - 2	Double sided tape Wire ties

This project needs multiple accessories and elements that do not come into single kit. You have following options in that case.

- You can partner with friends around who have Havi Elements kits with them.
- Can buy additional required elements and accessories
- Can perform this at a school or activity center which has Havi's Robotics Kits.
- Can contact us directly to get required elements & accessories to make this project

### The making

**Step 1** — Make two robotic cars. Refer How to make a robot or see the below video to prepare structure of your car for this project. You can also check how to make a robot car if you are making this project using Havi Robotic Car Kit.

**Step 2** — Prepare the circuit for both the cars.

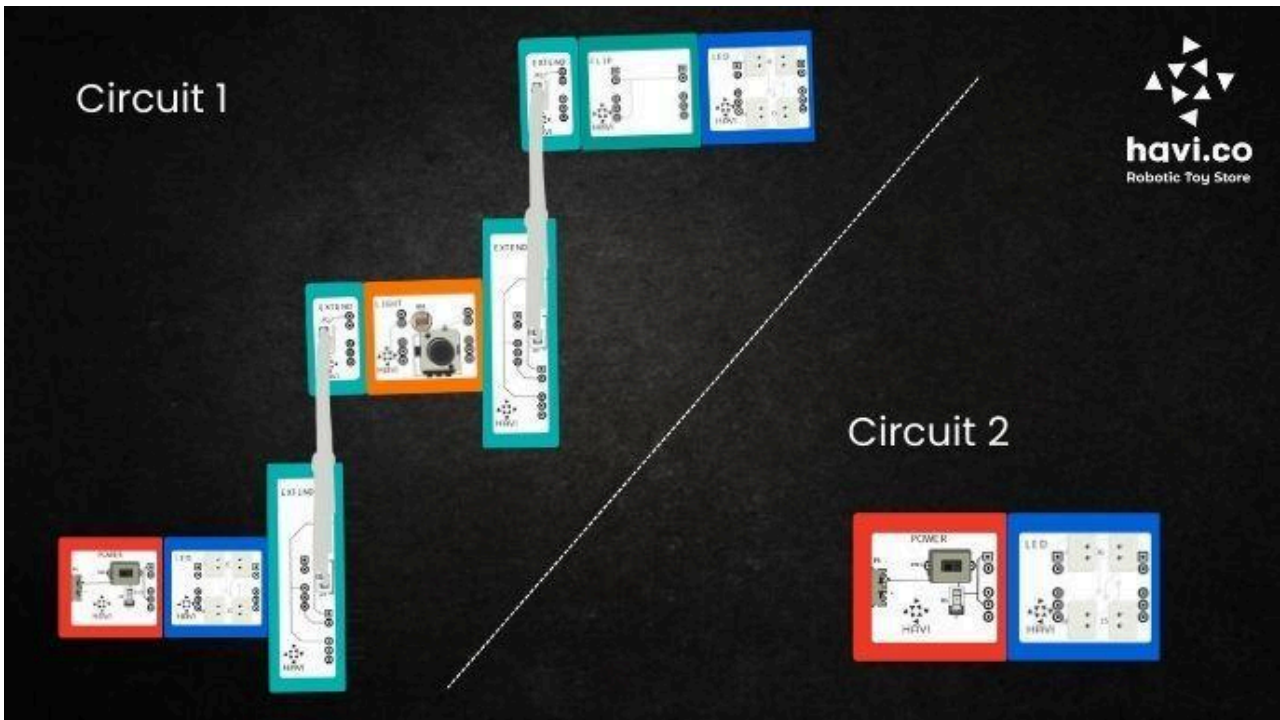

**Step 3** — Connect the LED cables with the LED Element.

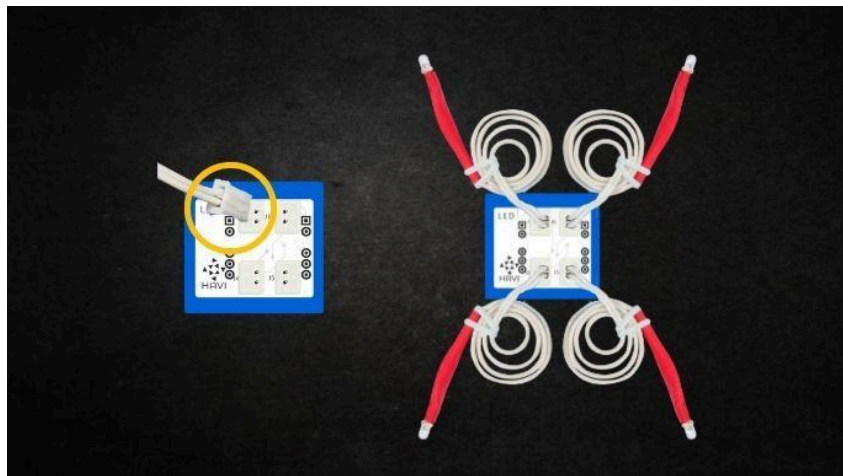

**Step 4** — For the car with circuit 1, stick the power bank on the backside of the car plate. Stick the LED cables in front corners using DST.

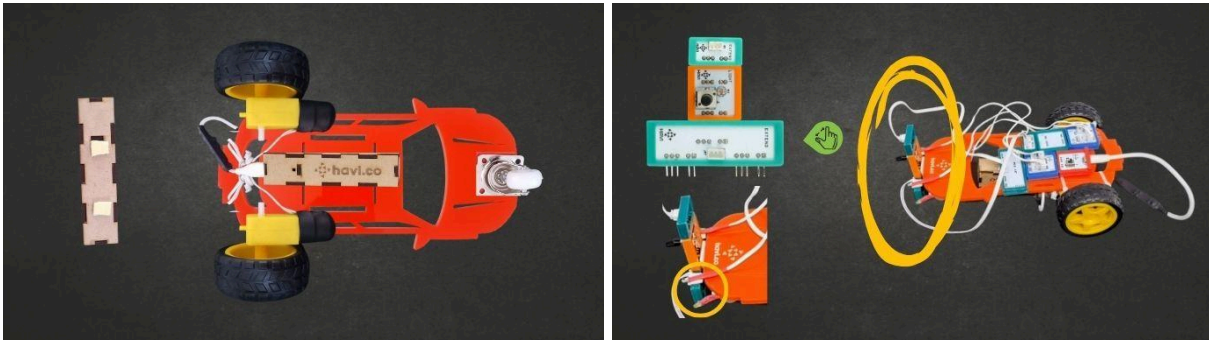

**Step 5** — For the car with circuit 2, stick the LED cables in front corners using DST.

**Step 6** — Tune the potentiometer of Light Element in such a way that it can detect the headlight of the opposite car at safe distance.



**Step 7** — Now, place both the cars in front of each other. Turn the Power ON. See how automatic dipper/dimmer car dims two of its headlights when there is another car at opposite side.

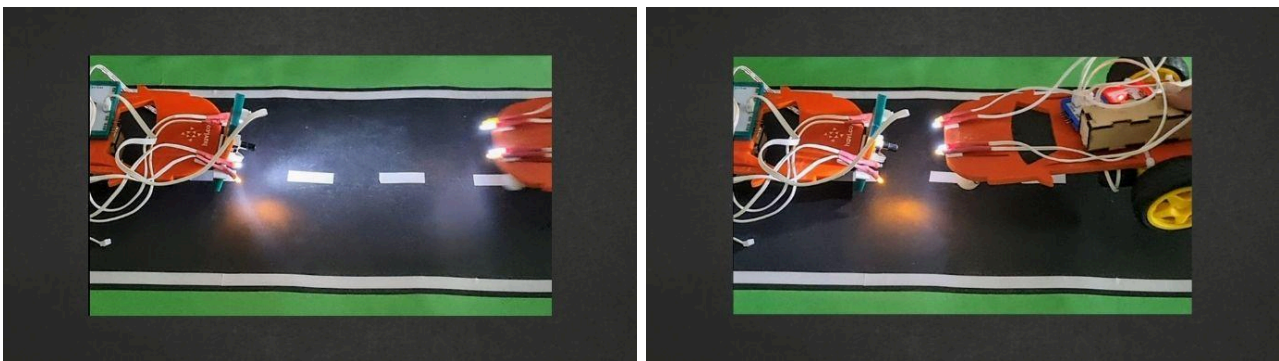

### How does it work?

Automatic dimmer/dipper car: As you can see in the circuit, one LED element is controlled by the light sensor, and another LED element is directly controlled by the power element. The Extend element is used to better position the circuit, and the Flip element is used to trigger the light sensor. Initially, when the circuit starts, four of the LEDs are ON, two are regular headlight LEDs and rest are dipper headlight LEDs. The Light Element sends a YES signal when it detects light, and the Flip converts it to NO. Initially, when there is no light from opposite headlights in front of Light Element, it sends a No signal to the Flip, and the Flip converts to YES. Hence, the dipper LEDs are ON. When the Light Element senses opposite light, it sends a YES signal to the Flip, and the Flip converts to NO, hence the two dipper LEDs go OFF. That's how the automatic dimmer/dipper headlight works. When no vehicle is on the opposite side, the dipper headlights are on, and when there is a vehicle on the opposite side, only the dimmer is on.

**Chapter 18**

# DIY Automatic water dispenser model using Havi Elements

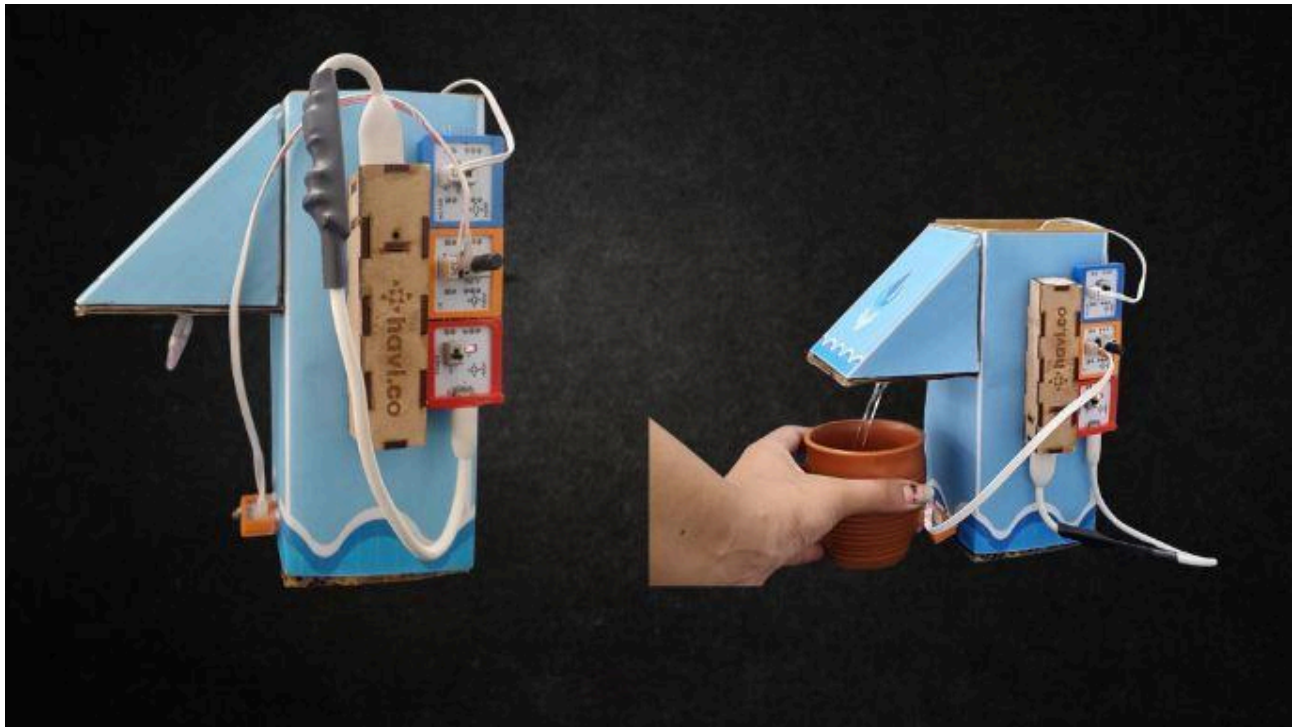

Have you noticed the automatic water bottle fillers in airports or the automatic water taps in malls, theaters, and hotels? These systems address the issue of water wastage while also offering a hygienic solution.

But did you know that you can create a prototype model of that using IR sensors or ultrasonic sensors?

In this blog post, let's explore how to build a DIY automatic water dispenser project model using Havi's robotics kit and cardboard. You can use the same model for making coffee or soup or lemonade dispenser as well. A STEAM project to execute in your science fairs.

What is automatic water dispenser?

Automatic water dispensers are machines that dispense water automatically when a bottle, glass, or object is nearby the dispenser outlet. They fetch water from pre-storage cans and dispense it when an object is nearby.

### Things you need

Elements	Accessories	Craft material
Power Motor IR	Submersible pump Power bank with USB Cable 3-pin cable	Disposable water bottle Card board Cutter Scissor Scale Pencil Glue Double-sided tape

## The making

### 1. The dispenser model

**Step 1** — Cut a disposable water bottle at the filler part. Then, cut a small rectangular slot from the open part of the bottle.



**Step 2** — Place the submersible pump into the open bottle as defined.



**Step 3** — Draw equal slots on the cardboard using a pencil. Then, cut a square as defined in the image.

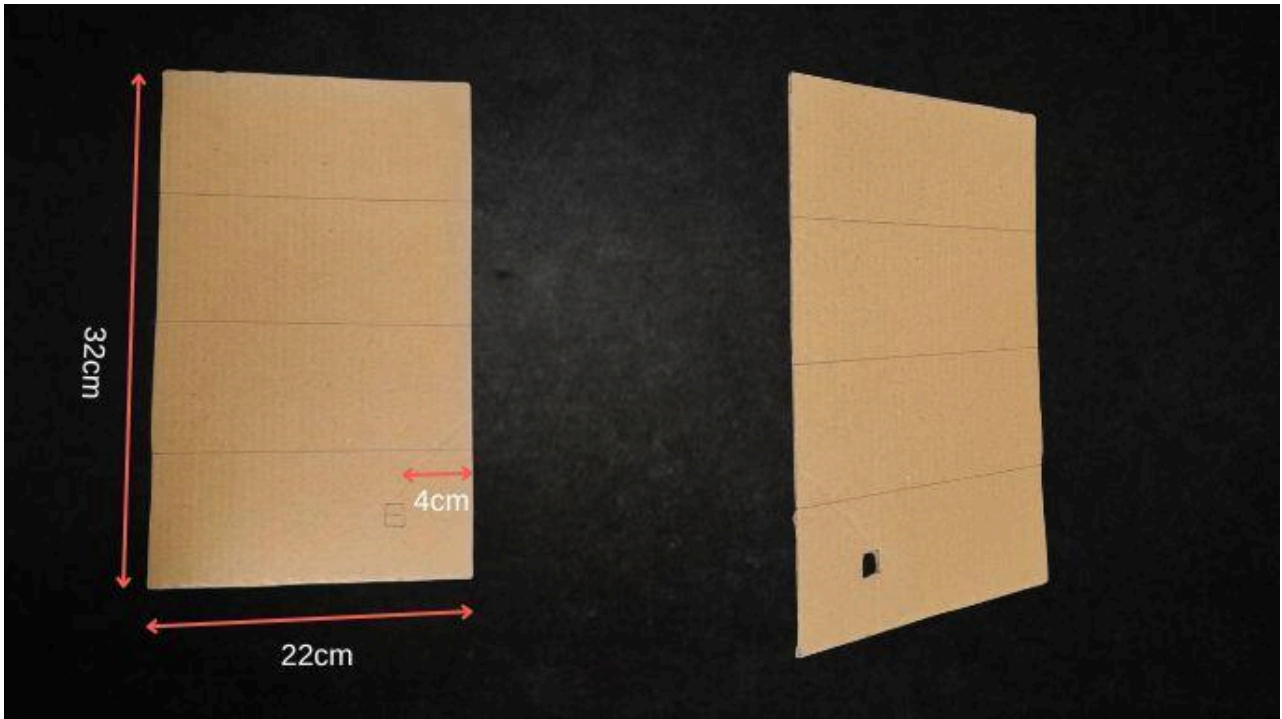

**Step 4** — Fold the cardboard from pencil marks to create a box shape. Use glue to stick the edges of the box together securely.

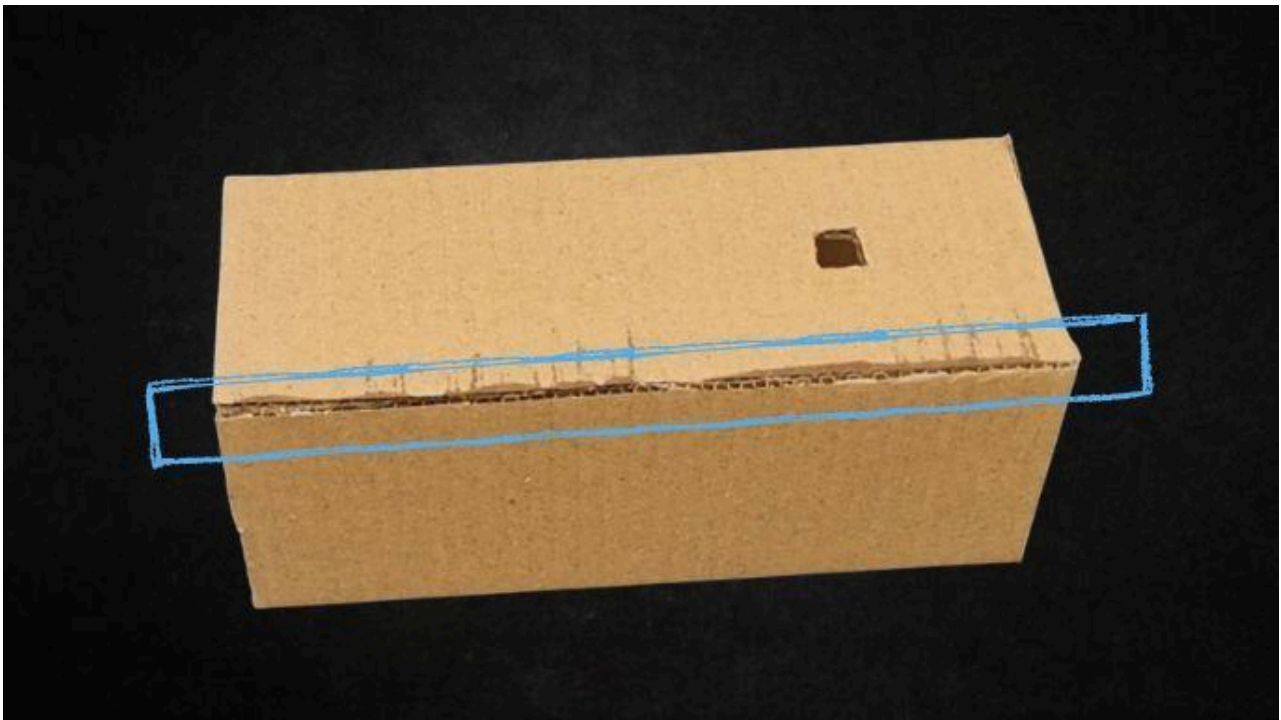

**Step 5** — Next, cut another square from cardboard and affix it over one side of the box in a manner that it covers one end of the box completely.

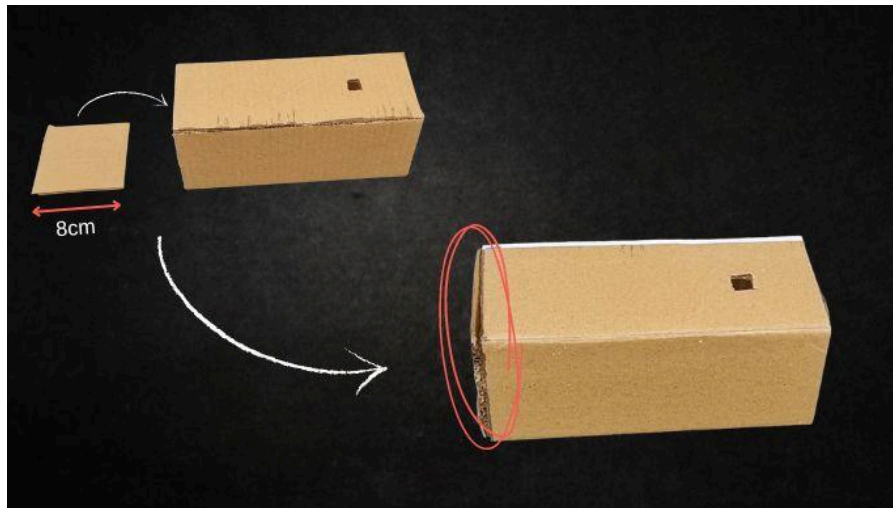

**Step 6** — Download the template provided. Cut & stick it over the box. There are two different templates provided. One for water dispenser model and another for coffee dispenser machine. You can use whichever you like. You can print it on sticker paper for direct application, or print it on regular paper and use glue to stick it to the box. Use A4 & A5 papers for print.

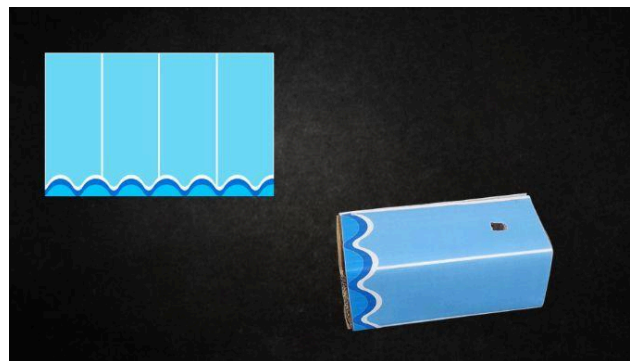

**Step 7** — Now, Cut a cardboard piece into a hexagon shape. Fold the board as defined.

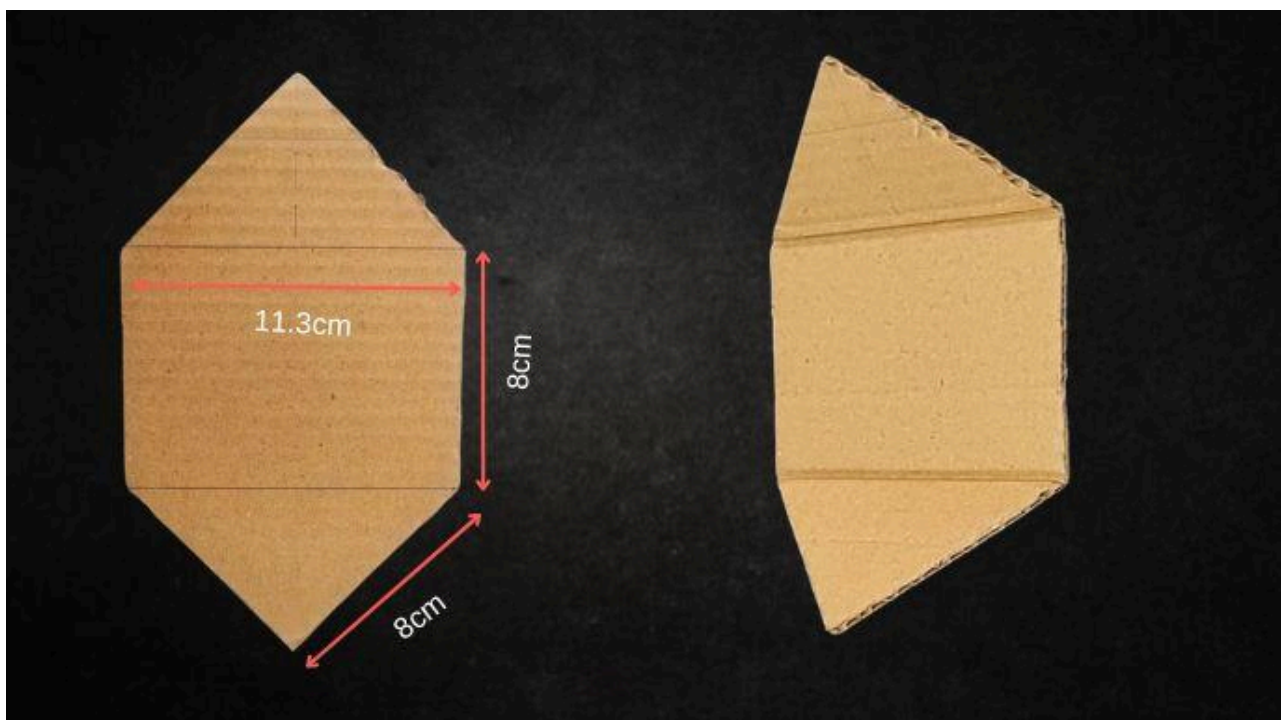

**Step 8** — Cut a square piece of cardboard and then make a small square slot as specified.

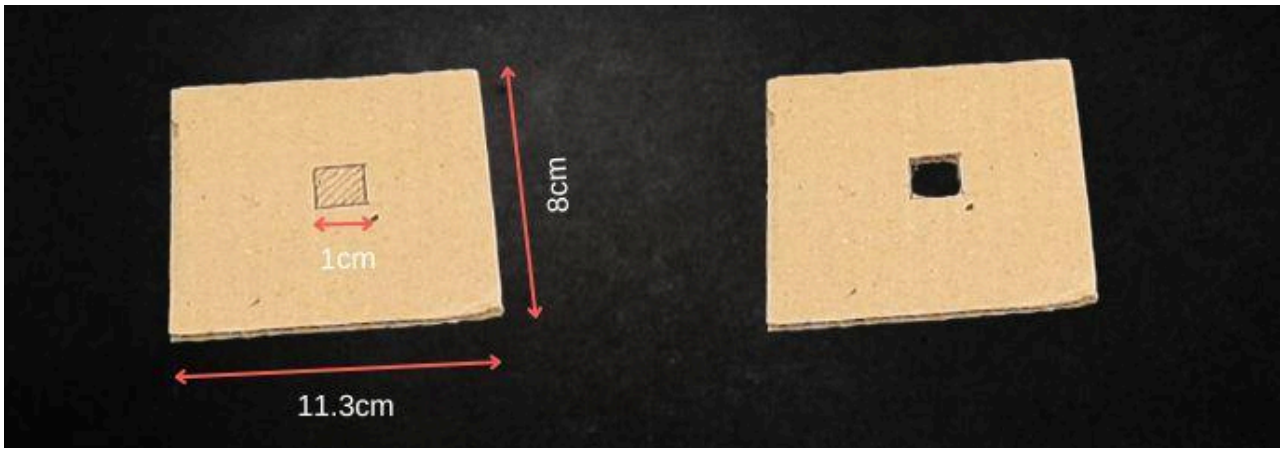

**Step 9** — Stick the square shaped piece onto the hexagon piece.



**Step 10** — Cut & stick the provided template over it.

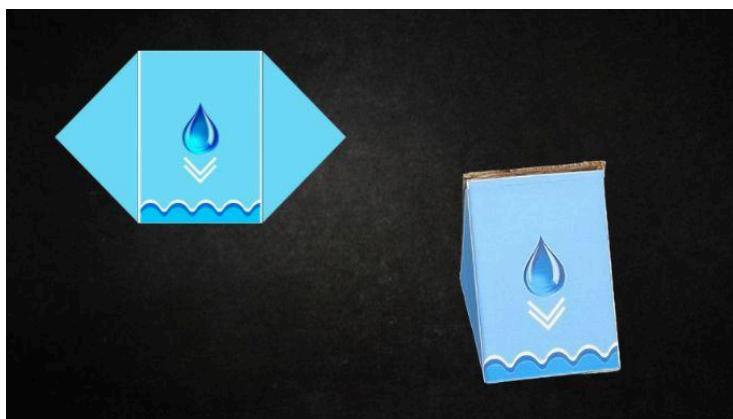

**Step 11** — Attach the small hexagon part onto the box we made earlier.

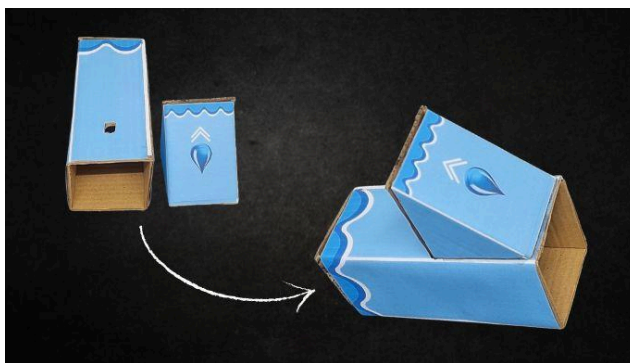

**Step 12** — Snap the circuit: Power + IR + Motor. Connect IR pair with 3-pin cable.

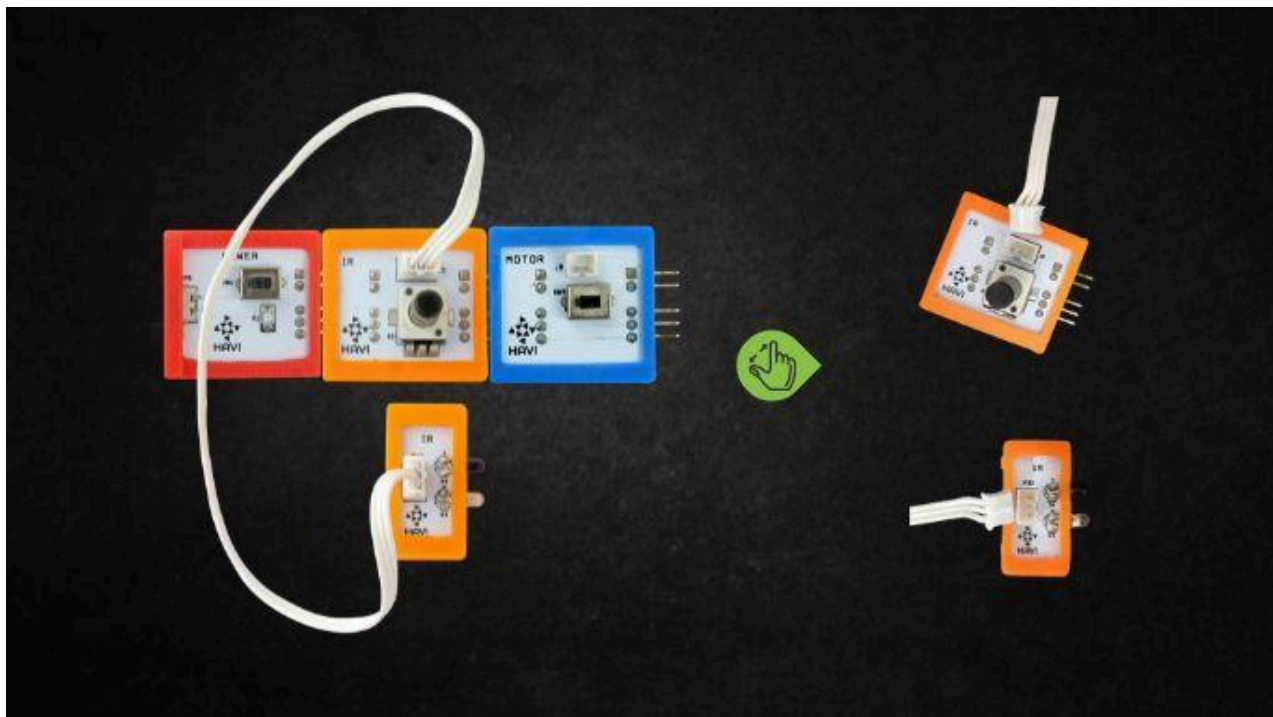

**Step 13** — Connect the power bank to the circuit using a USB cable. Affix the circuit and power bank onto the box using double-sided tape.

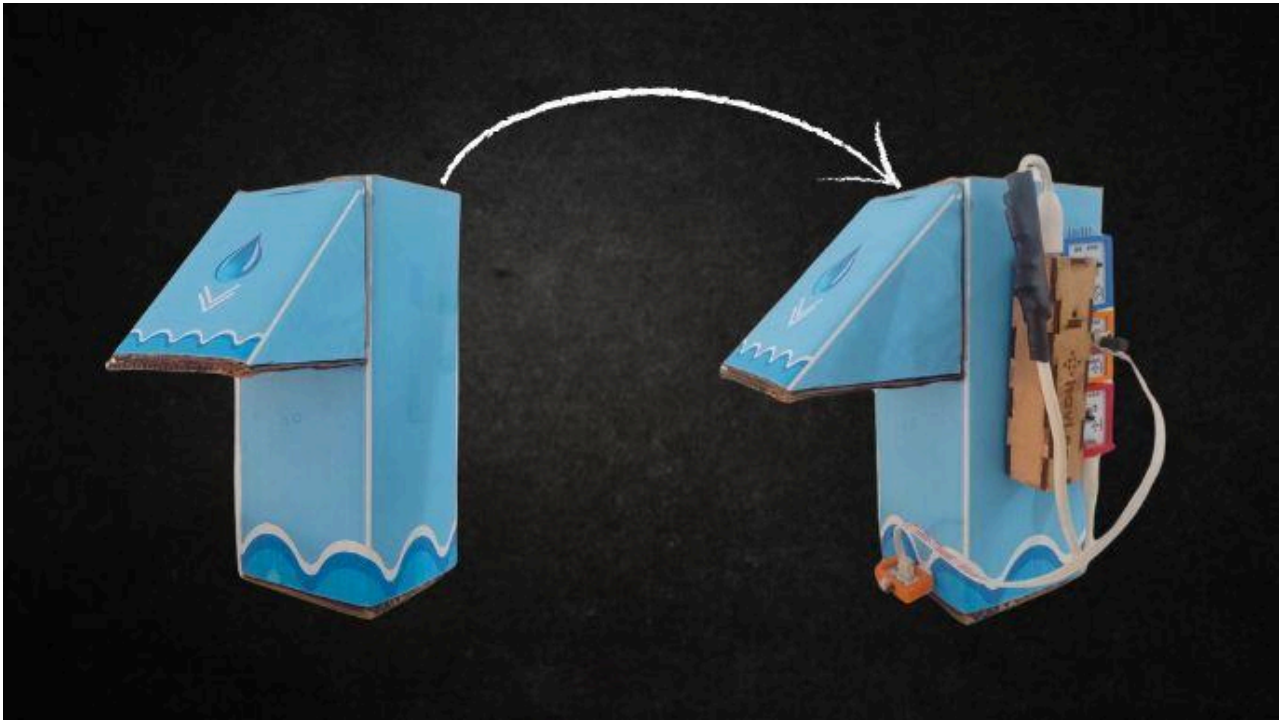

**Step 14** — Place the bottle into the box.

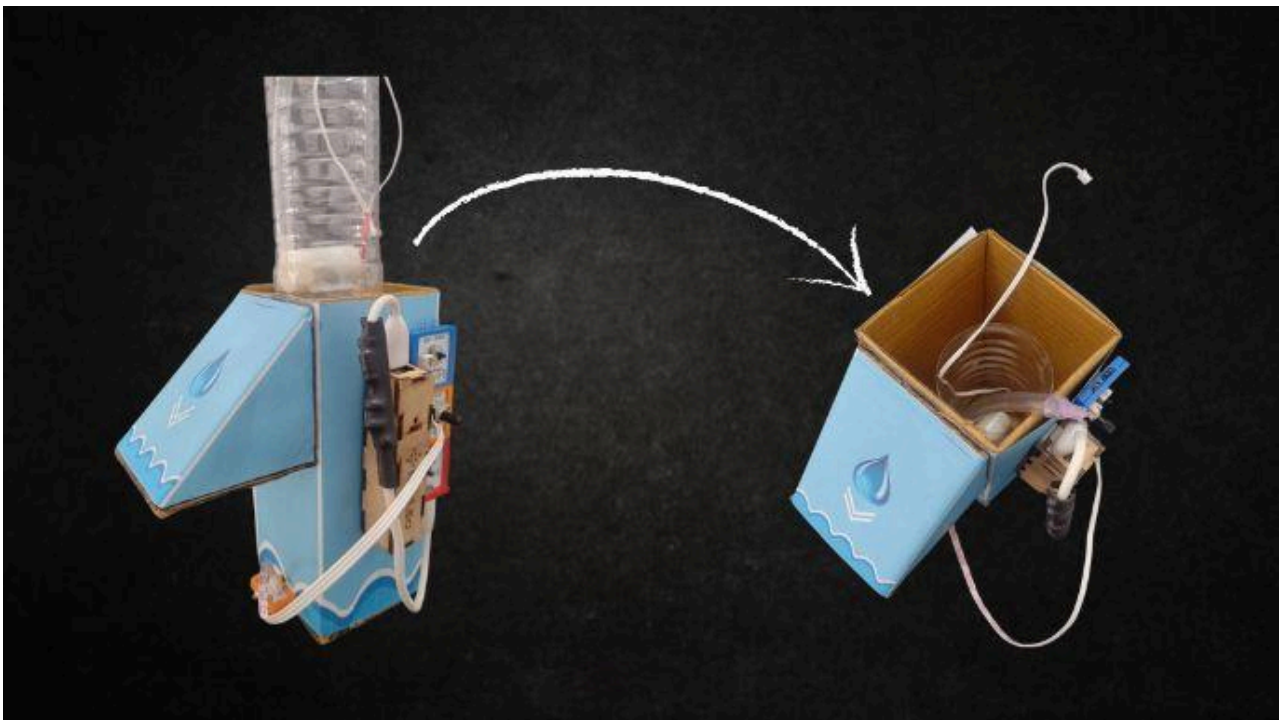

**Step 15** — Pass the water pump nozzle through the square slot of the box. Note the placement of the small IR sensor. Connect the water pump with Motor Element.

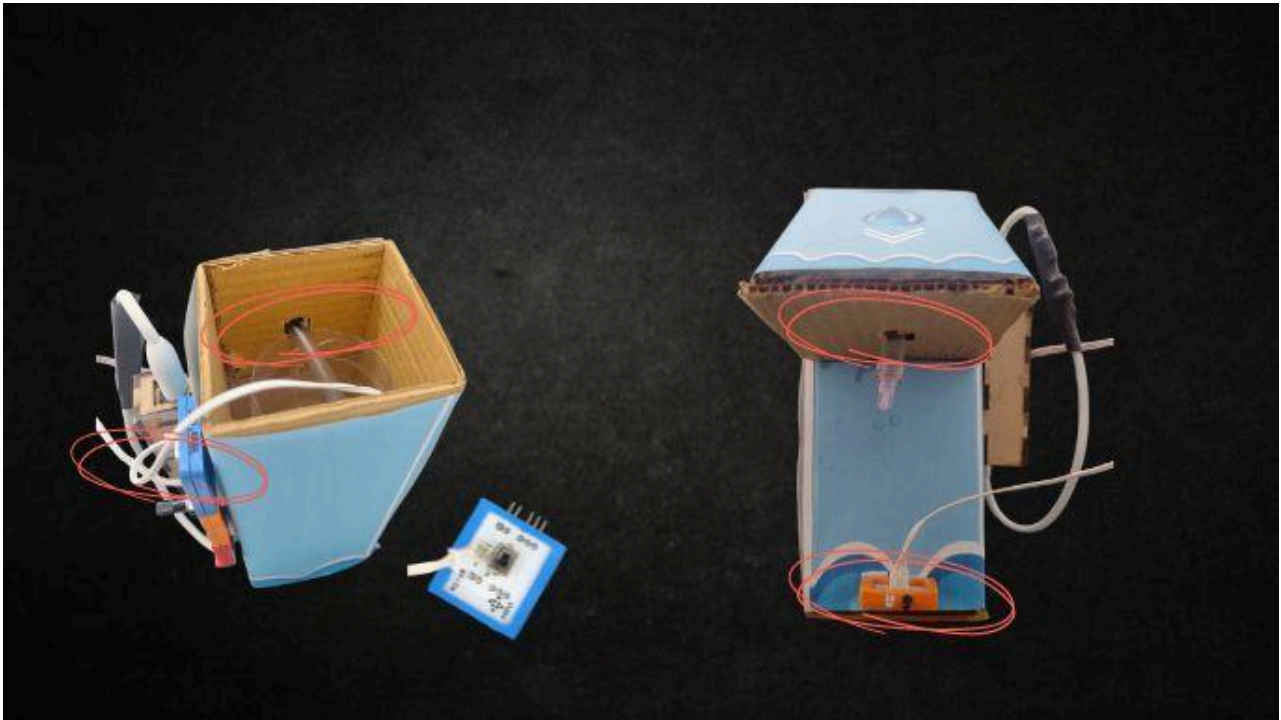

**Step 16** — Adjust the potentiometer of the IR Element to the middle position so that the sensor can detect the glass at an adequate distance.

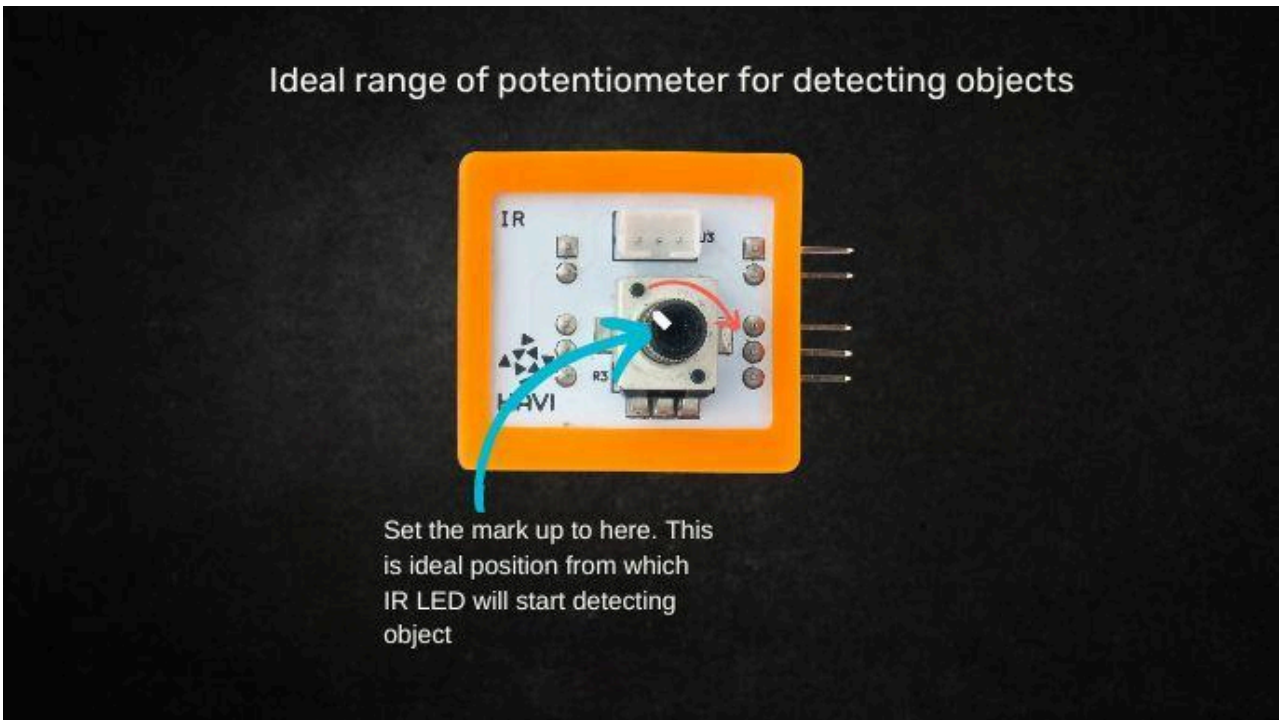

**Step 17** — Fill the bottle with water. Water should not touch the power bank or circuit.

**Step 18** — Turn the power ON. Keep a glass near the water dispense outlet(i.e. water pump nozzle).

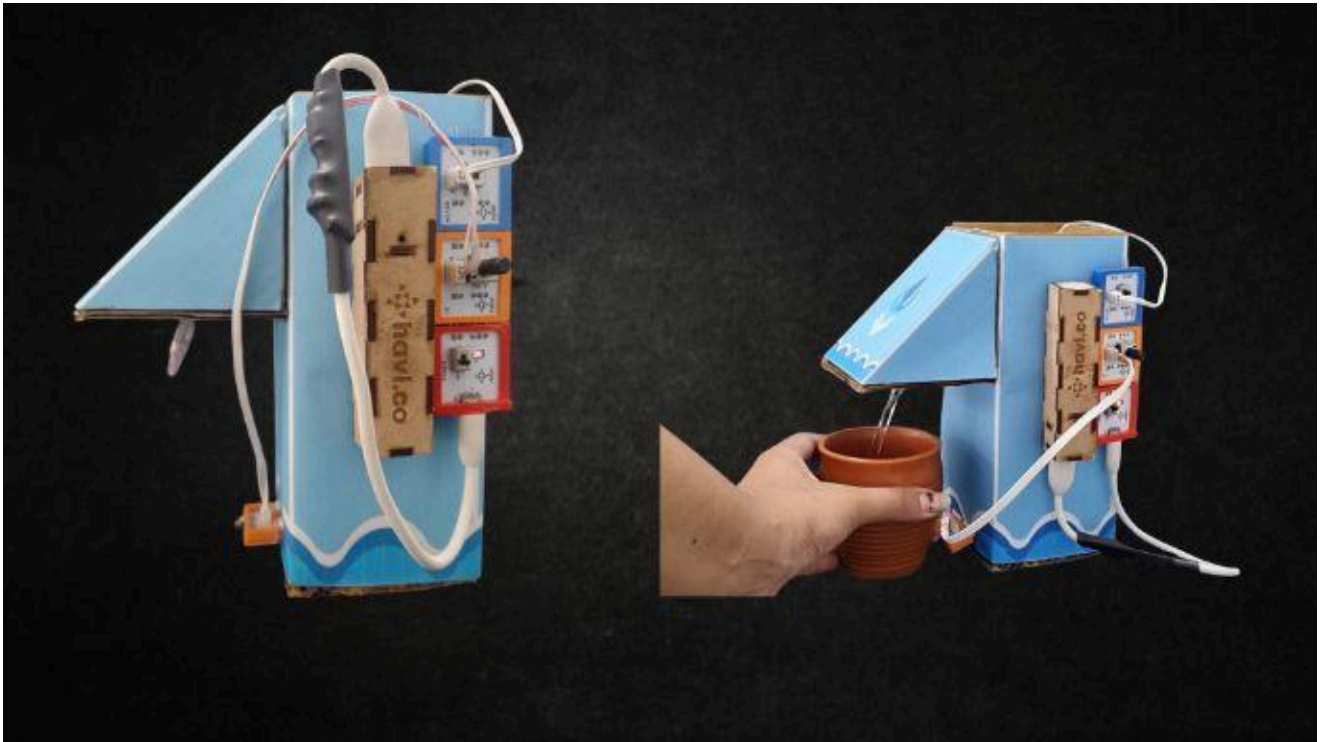

### How does it work?

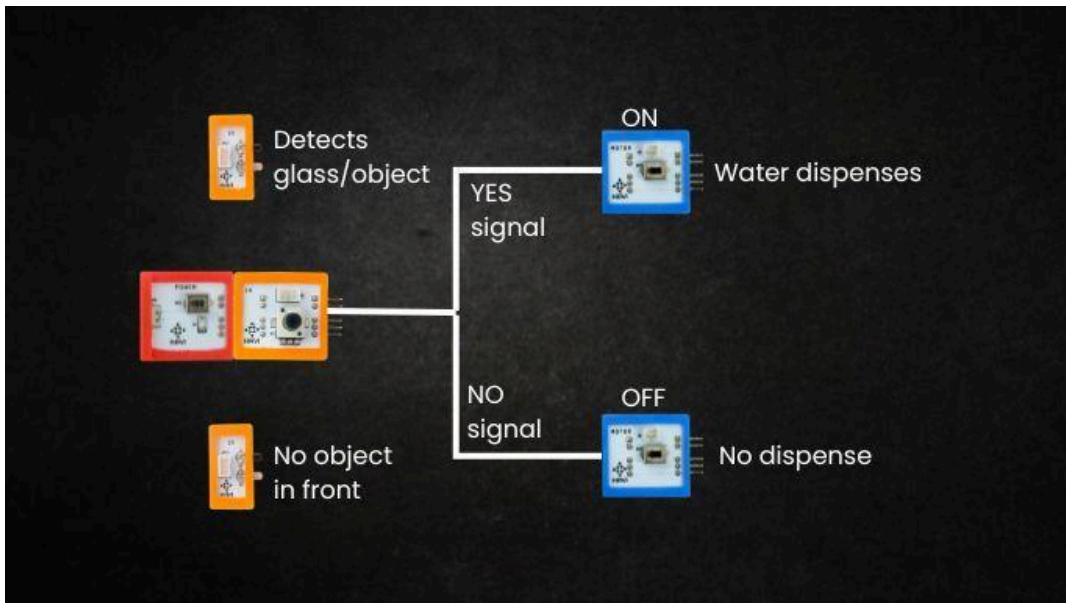

Here, the water dispenses automatically when the glass is near IR LED and stops when glass is far away from IR LED. When you switch on the Power Element, the power bank passes the stored current to the Power Element. Subsequently, the Power Element transfers the current to the connected IR Element. The IR Element passes YES only if the connected IR LED detects any object nearby. In rest cases, IR Element passes NO signal. Hence, when no object(here, glass) is near IR LED, IR Element passes NO signal to connected Motor Element, hence the pump won't dispense water. When an object is near an IR LED, IR Element passes a YES signal to the connected Motor Element, hence the pump dispenses water. So, be ready to prepare this project to present in your upcoming science fair. This could be one of the benchmark projects in the "Save water" category & smart home solutions. Contact us to get customized pack to make this project.

Chapter 19

# How to make a river cleaning robot project using propeller



Nitya was keen to make a river cleaning robot during her last science fair. Her intent was neither to win the show nor to impress her friends. Her sole objective was to bring awareness about this very important topic of clean rivers amongst her peers and visitors.

Environment sustainability is not just a buzzword but the need of the hour. Climate change, polluted water, ocean health are the major issues to be solved. The impact of these issues affects every domain in small or large amounts. In-fact clear water and sanitation is one of the 17 sustainable goals set by UN.

One great way to bring awareness is to encourage children to build DIY science projects that focus on solving these environmental issues.

So in this blog post, we are making a project that addresses the issue of water pollution. Yes, a river cleaning robot using havi elements and a propeller. This river cleaning robot project has two parts. 1. We will make a propeller boat first. 2. Equip the boat with a net that collects the garbage from the surface of the water, to convert it into a river cleaning boat.

This water cleaning boat project can be your next science fair STEM project on environment sustainability.

### Things you need

Elements	Accessories	Craft material
Power Motor - 2	Geared motor Power bank with USB Cable Wheel Propeller Bottles - 2	Double-sided tape Wire ties with lock Cable ties White open weave bandage Transparent plastic

		Thin metal rod/wire
--	--	---------------------

## The making

**Step 1** — Attach the geared motor vertically at the back side (opposite to the side where the logo is engraved) of the car plate tightly using wire ties.

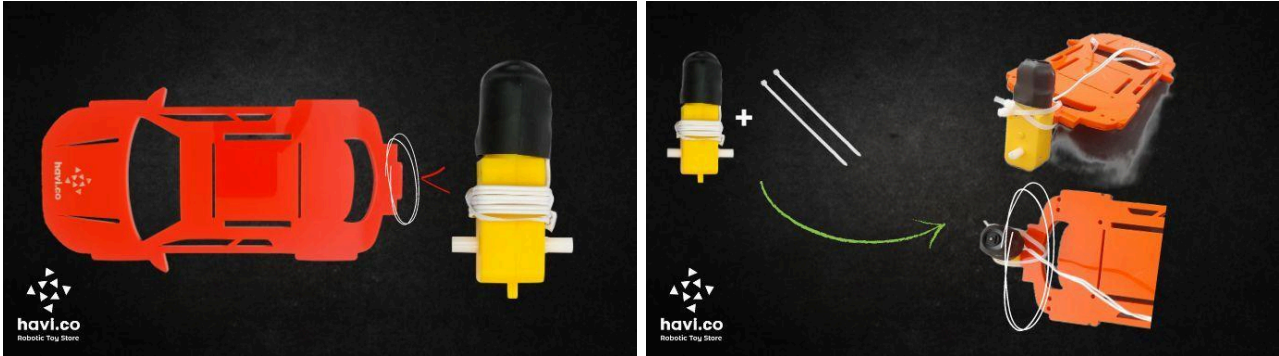

**Step 2** — Stick two medium-sized leak-proof bottles using double-sided tape. Make sure that the caps are tightly closed and are facing the opposite directions.

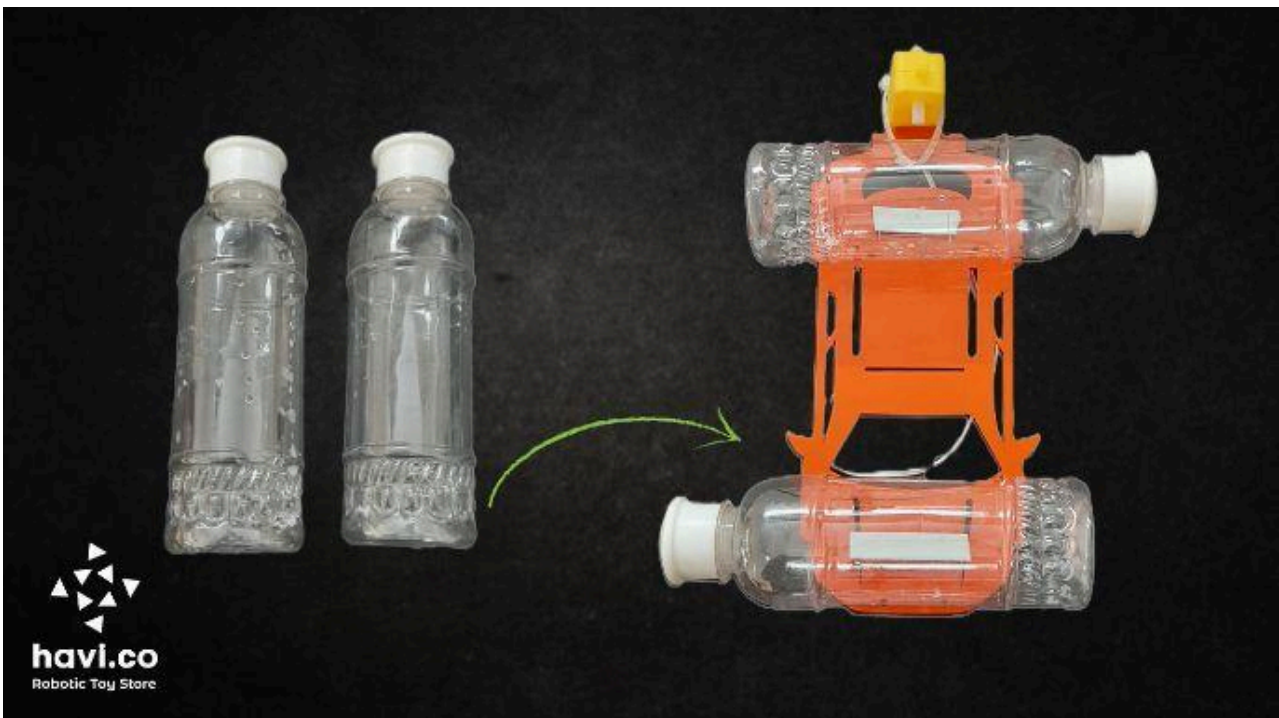

**Step 3** — Remove the wheel grip. Stick the propeller over the yellow ring of the wheel using DST. Do not forget to fix the wheel grip again after completing the project.

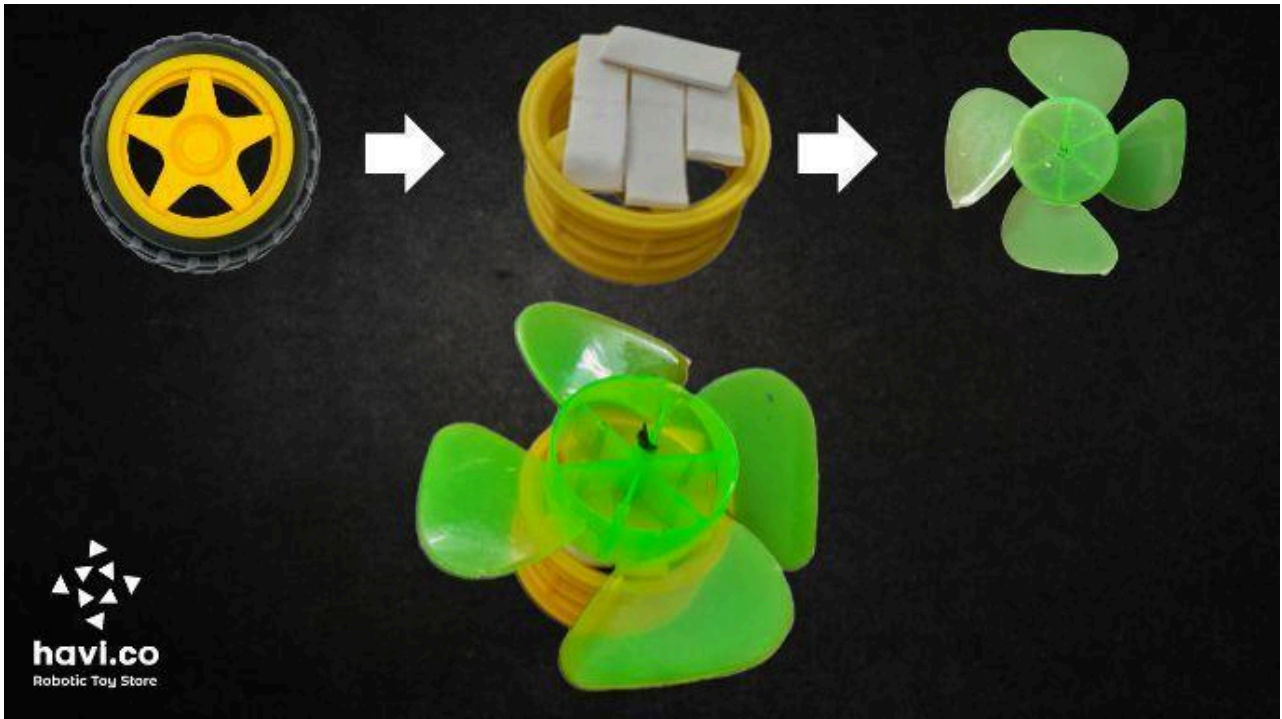

**Step 4** — Connect the geared motor with the wheel by matching the shaft with the slot.

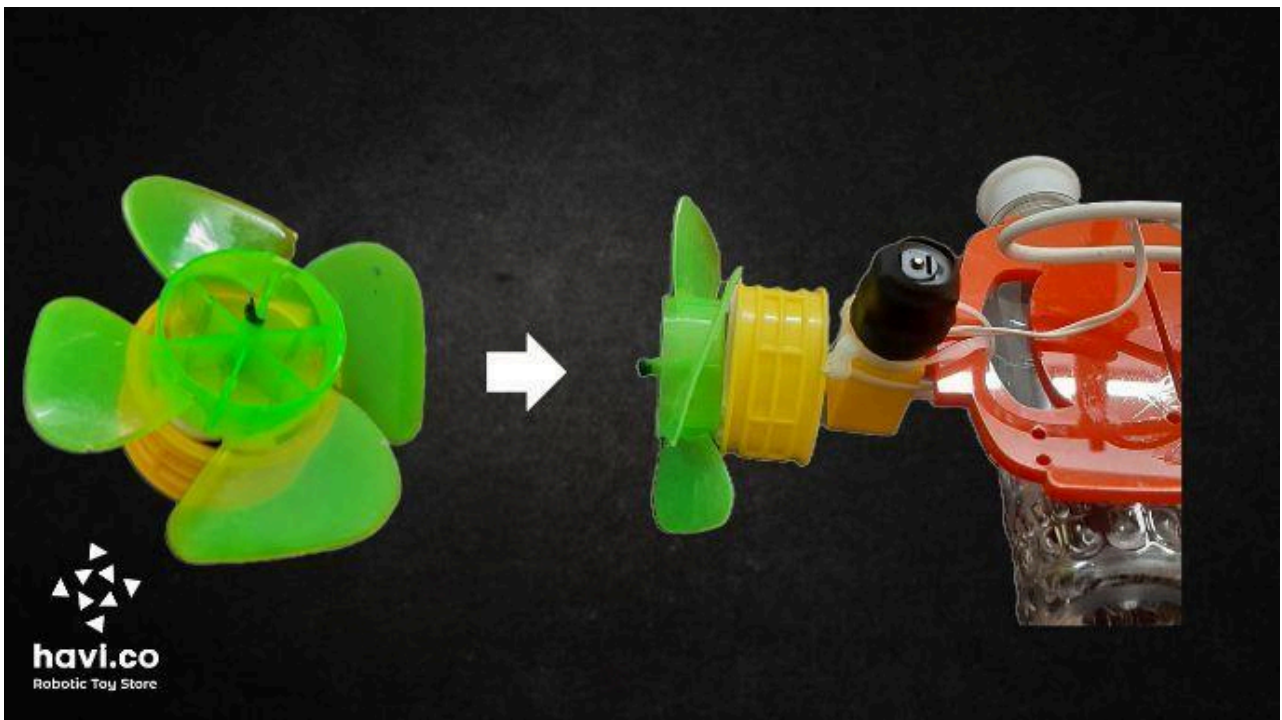

**Step 5** — Snap the circuit: Power + Motor. Connect the power bank using the USB cable. Connect the geared motor with the motor element.

**Step 6** — The river cleaning boat is going to float over the water surface. So, to protect the circuit & power bank from water, wrap the circuit using transparent plastic. Then stick that over the car plate using DST.

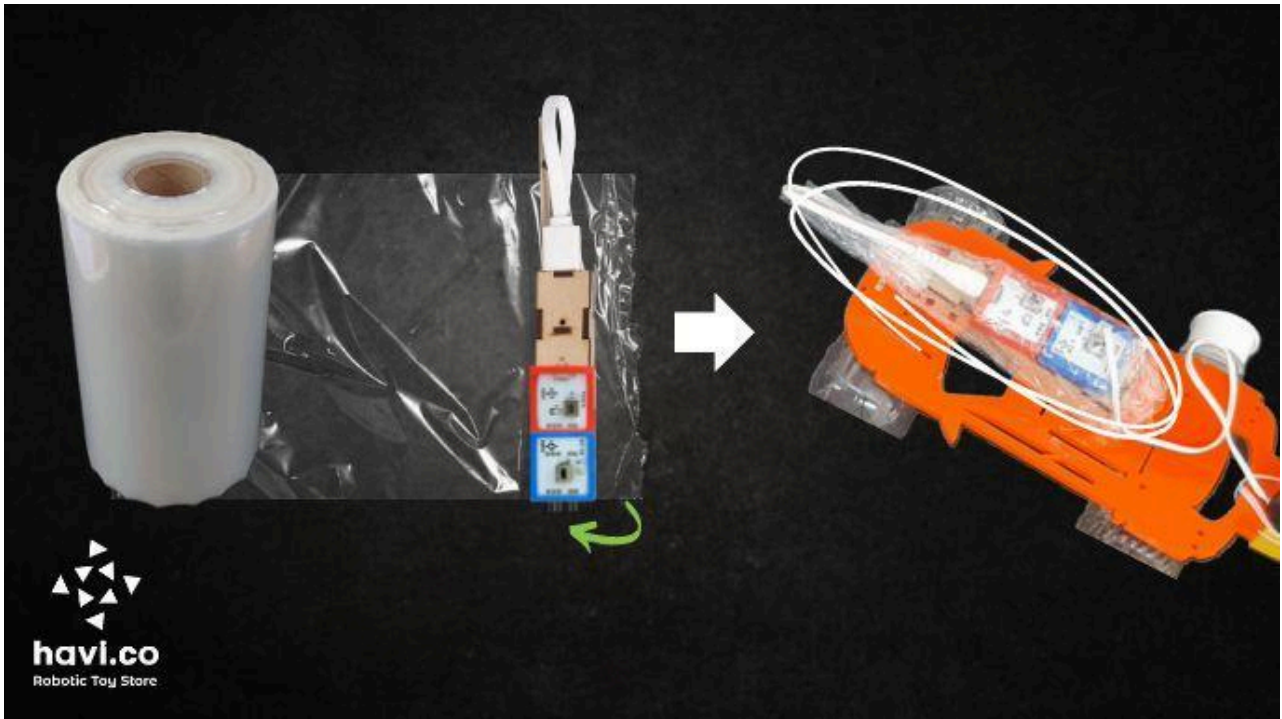

**Step 7** — We have made a propeller boat so far. Let's make a filter net or garbage collector to convert this into a river cleaning robot. Take sturdy but bendable metal wire and mold it into C shape as shown. Take a piece of white open weave bandage. Cover the wire with the corners of the piece. Fix it using simple cable ties. Make the filter net structure.

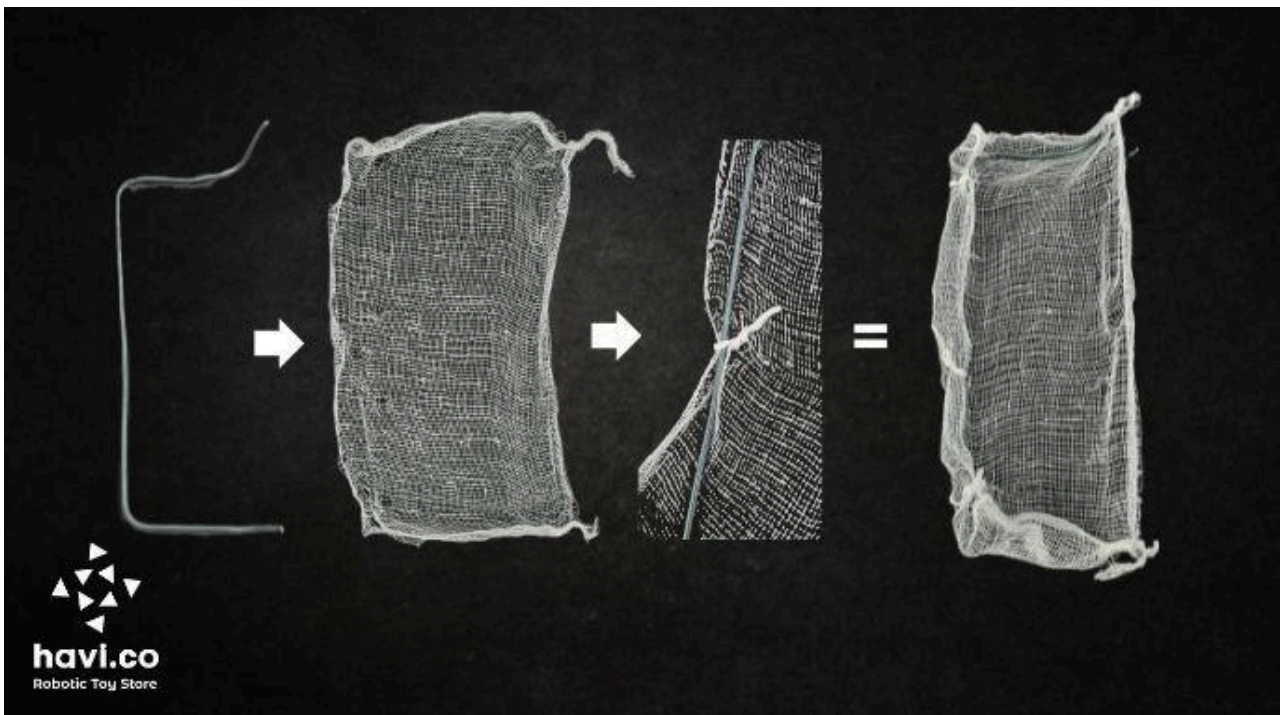

**Step 8** — Now place and connect the prepared net structure at the front of the boat model (where the logo is imprinted) using cable ties.

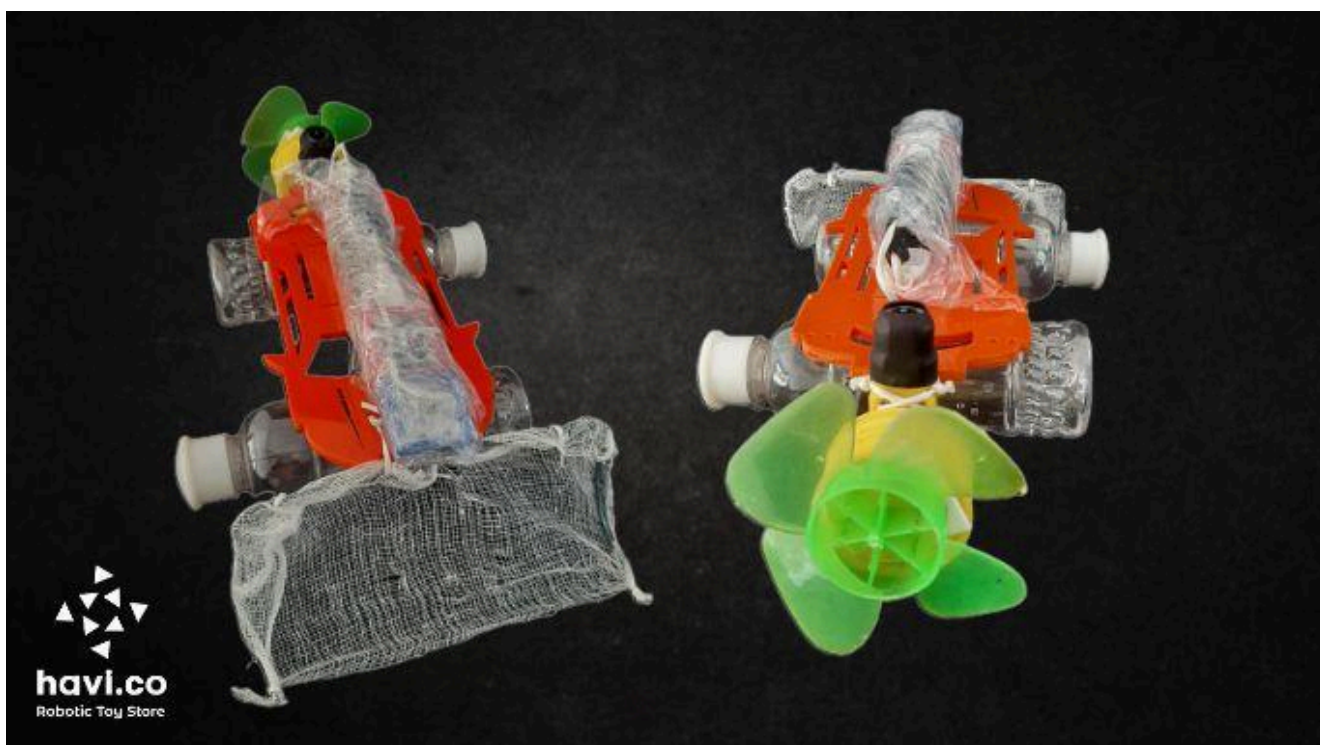
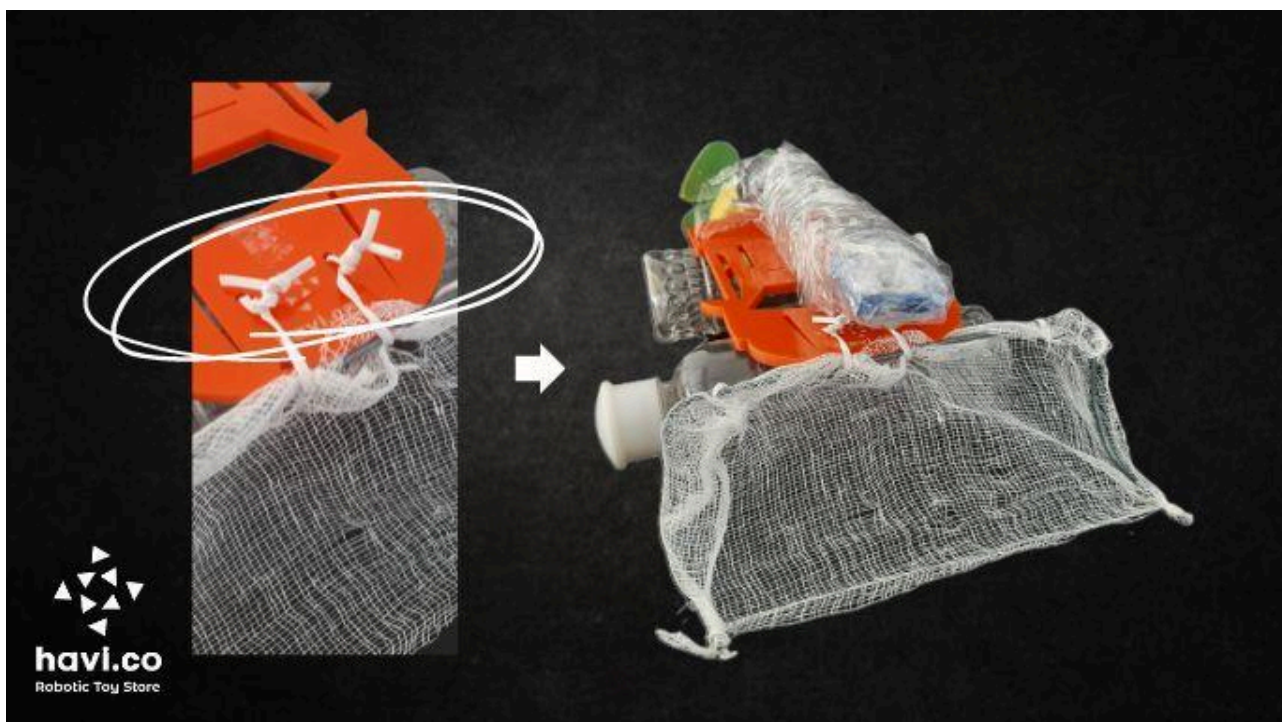

Place the DIY propeller boat in a big enough container of water. Put some wrappers, papers etc into the container. Now, place your river cleaning boat on the water and turn the power element on.



Your water cleaning propeller boat project is ready to collect the surface waste.

### How does it work?

The DIY river cleaning robot has two empty bottles. What do we mean by empty? It's not empty, it's filled with air. Since the bottles are leak proof, the air keeps the boat floating in the water. The next important mechanism of our river cleaning robot is the propeller. The placement and rotation of the propeller moves the water that results into the motion of the boat. When the propeller rotates, it creates a force that pushes the water backwards, and this force makes the boat move forward. So, as soon as we turn ON the power element, it passes current to the motor element and the connected geared motor starts. With that, the attached propeller starts spinning and the boat moves. As soon as the DIY boat moves, the connected filter net starts collecting the garbage from water or river surface.

### Advantages when implemented in the real world

Water cleaning boats are helpful for reducing surface water waste and can be used in rivers, lakes and all other water bodies. Industries can make such boats with high powered propellers in real life. Also, these robots, when made with high capacity collectors, can be helpful for collecting the Algae from the water surface. So children, parents, and teachers, what are your thoughts? Build this super cool environmental DIY STEM project working model for your next science fair and contribute towards environmental awareness.

## Chapter 20

# How to make vacuum cleaner

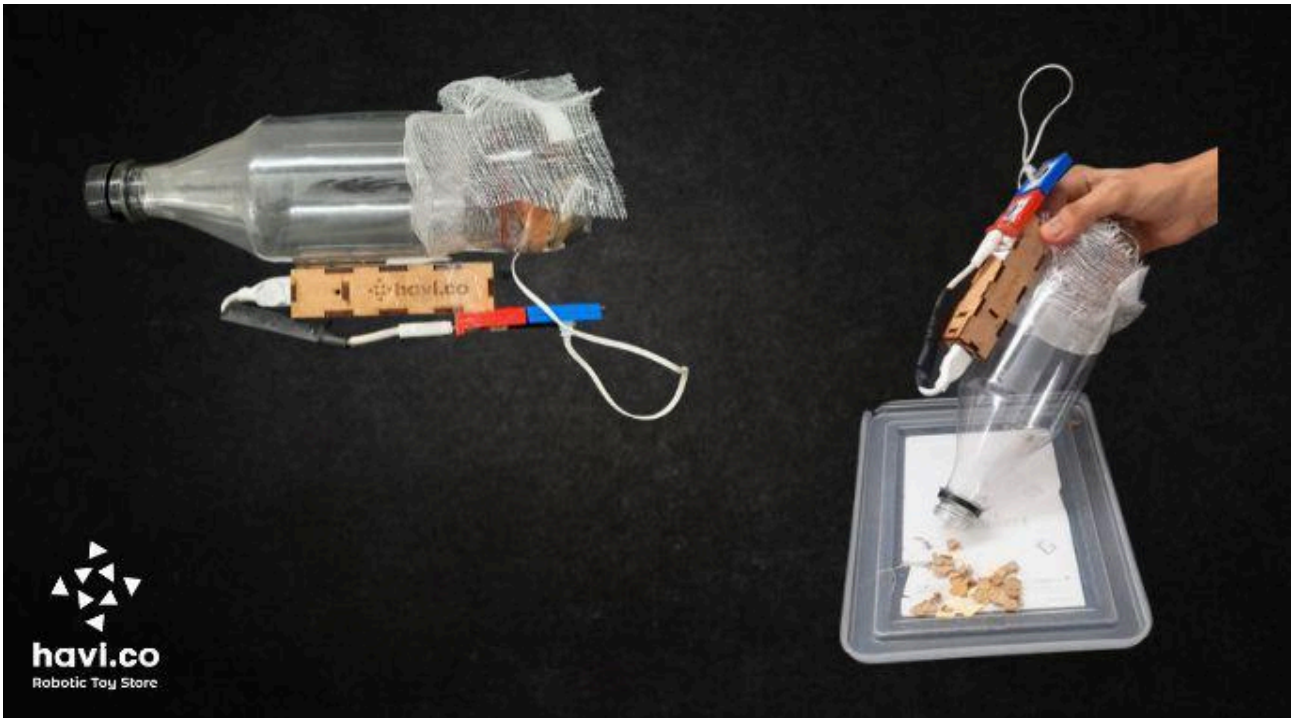

DIY projects with havi elements are always fun. That’s because they are STEM + Arts, that is STEAM. In this blog, we will see how to make a DIY vacuum cleaner model at home.

With the advancement of technology, various machines have made our life easier. Many machines are designed to solve specific human problems. One of them is a vacuum cleaner.

Let’s first understand what a vacuum cleaner is and then will see how to make an easy vacuum cleaner project at home.

What is a vacuum cleaner?

A vacuum cleaner is a machine that sucks small particles of dust and dirt from surfaces like floor, carpet, sofa, car etc. It is an electronic device and uses the concept of air pressure and suction to clean the surface. Mostly, vacuum cleaners are used in domestic applications, but there are industrial applications too.

How to make vacuum cleaner at home?

Now, let’s make a prototype vacuum cleaner using plastic bottles and havi elements. You can make 100+ such STEAM and robotics projects using Havi’s robotics kit for beginners.

### Things you need

Elements	Accessories	Craft material
Power Motor	Gearless motor Power bank with USB Cable	Plastic bottle White open weave bandage Cardboard Compass Cutter & scissors Double-sided tape

## The making

**Step 1** — To make the vacuum cleaner at home, first, let's cut a plastic bottle as defined in the image.

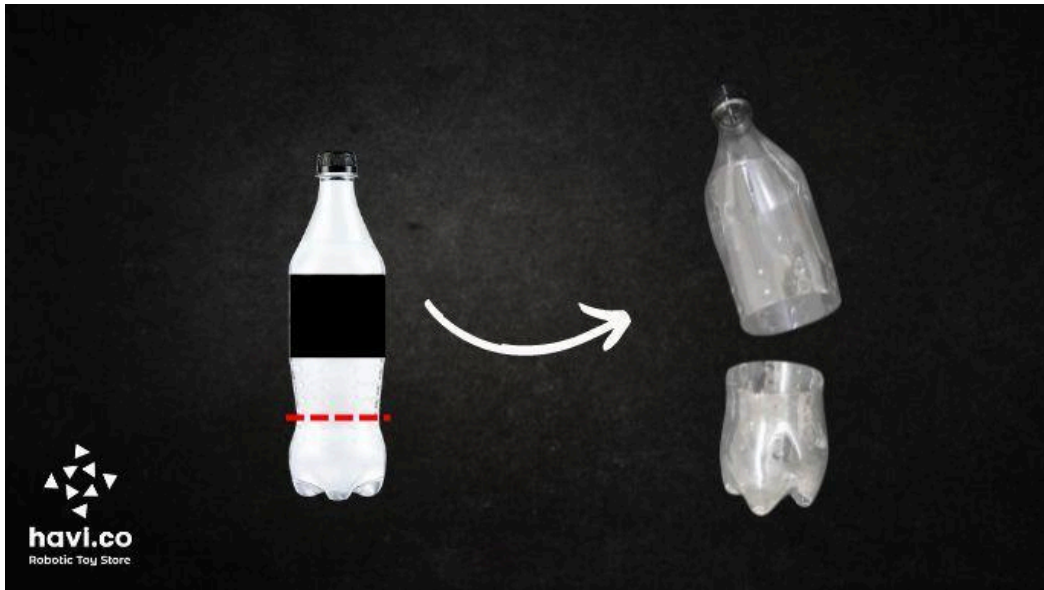

**Step 2** — Take the bottom part of the bottle. Make one hole at the side and 5 holes at the bottom of the plastic bottle.



**Step 3** — Cut a disc from cardboard that fits tightly into the bottom of the bottle. In the center of the disc, draw a square as per the size of the gearless motor.

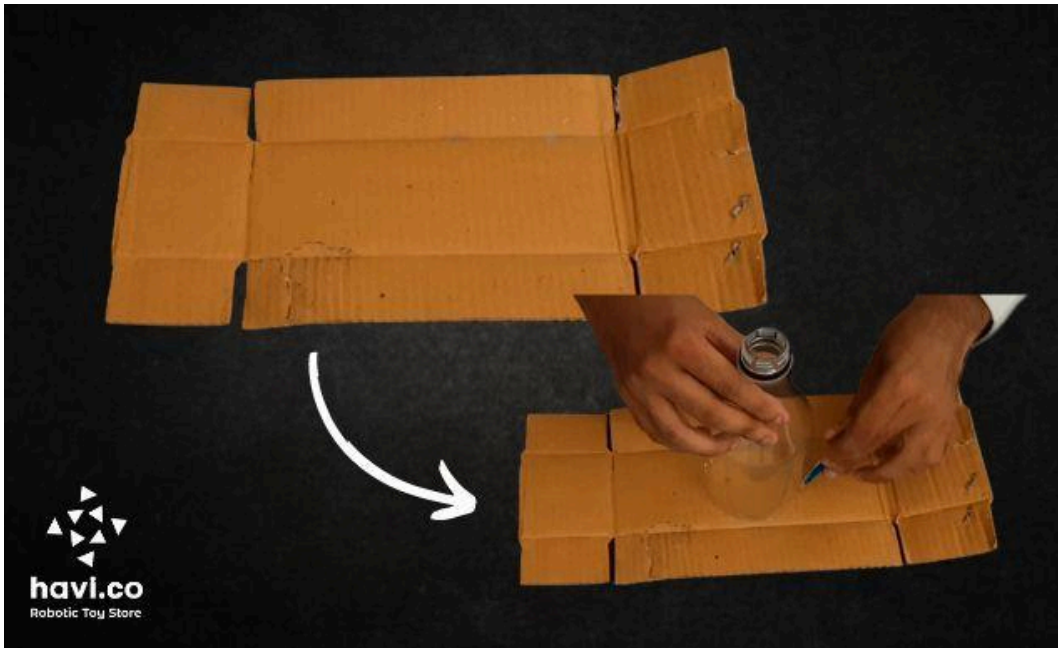

**Step 4** — Cut the triangle shapes at three different places of the disc. Cut the square to fit the gearless motor.

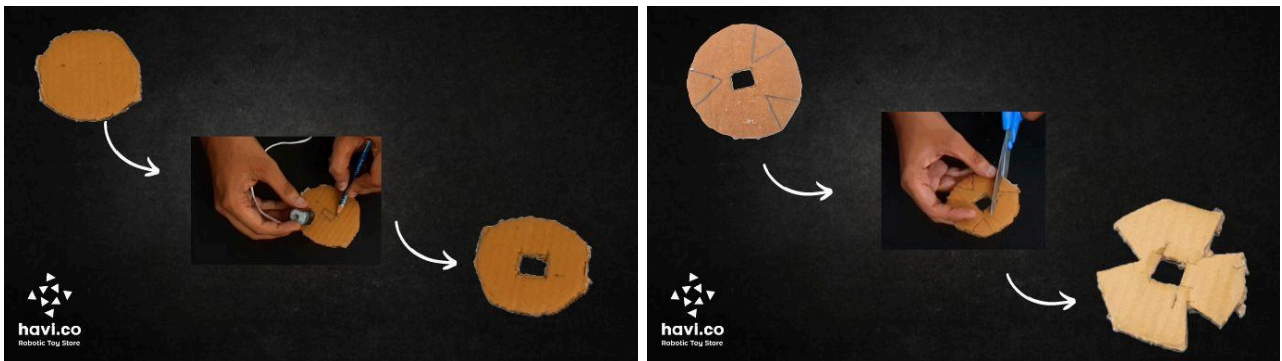

**Step 5** — Put the propeller into the shaft of the gearless motor. Fix the gearless motor at the center square of the cardboard piece.



**Step 6** — Insert the propeller setup into the bottom part of the bottle.

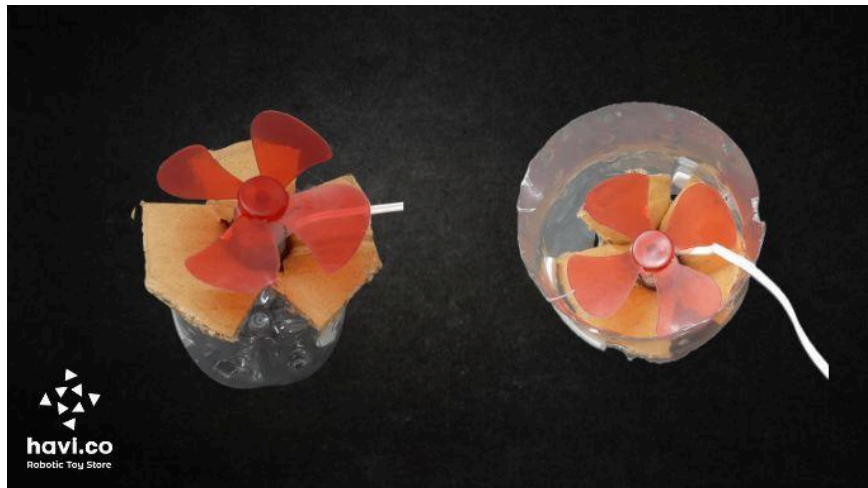

**Step 7** — Snap the circuit: Power + Motor. Connect the circuit with the powerbank using a USB cable.

**Step 8** — Stick the circuit over the power bank using double-sided tape or transparent tape.

**Step 9** — Pass the cable of the gearless motor through the hole of the bottle and connect it with Motor Element.

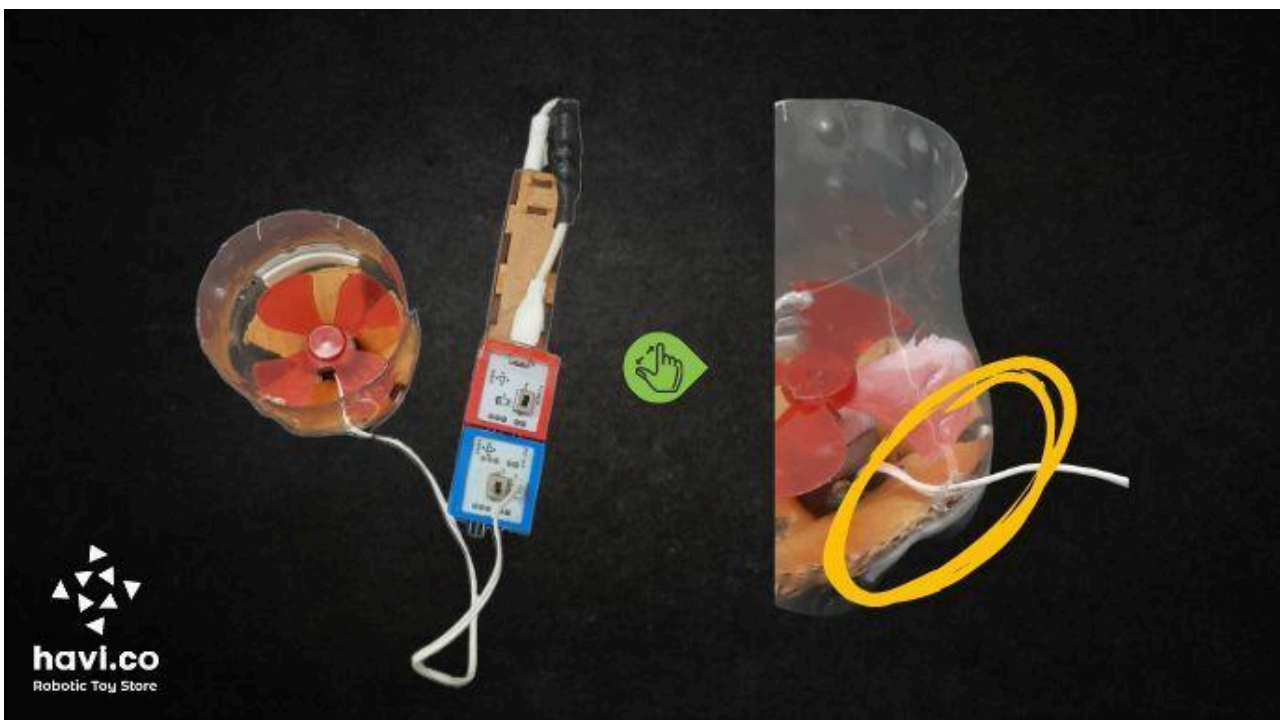

**Step 10** — Cover this setup with white open weave bandage piece and fix the other part of the bottle over it.

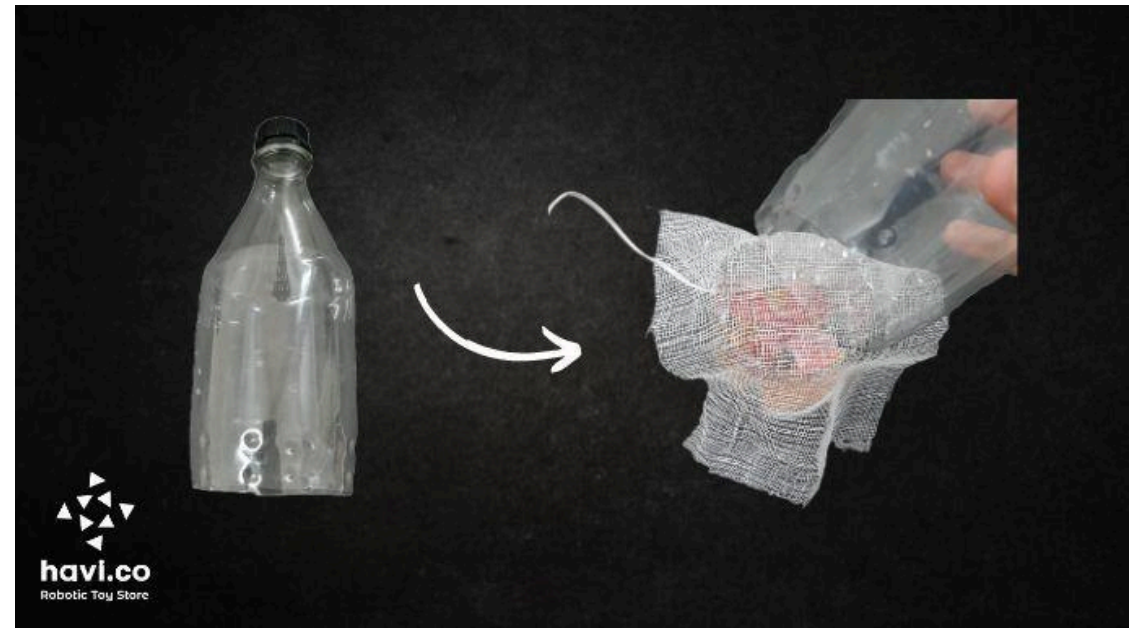
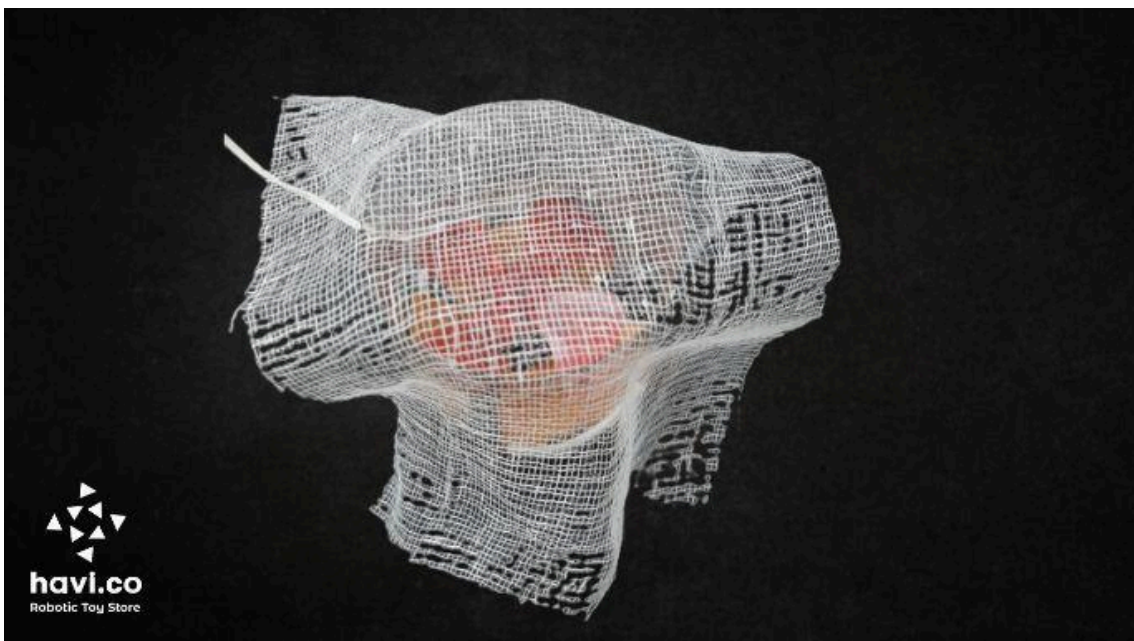

**Step 11** — By using double-sided tape, Stick the power bank on the bottle. The vacuum cleaner is ready.

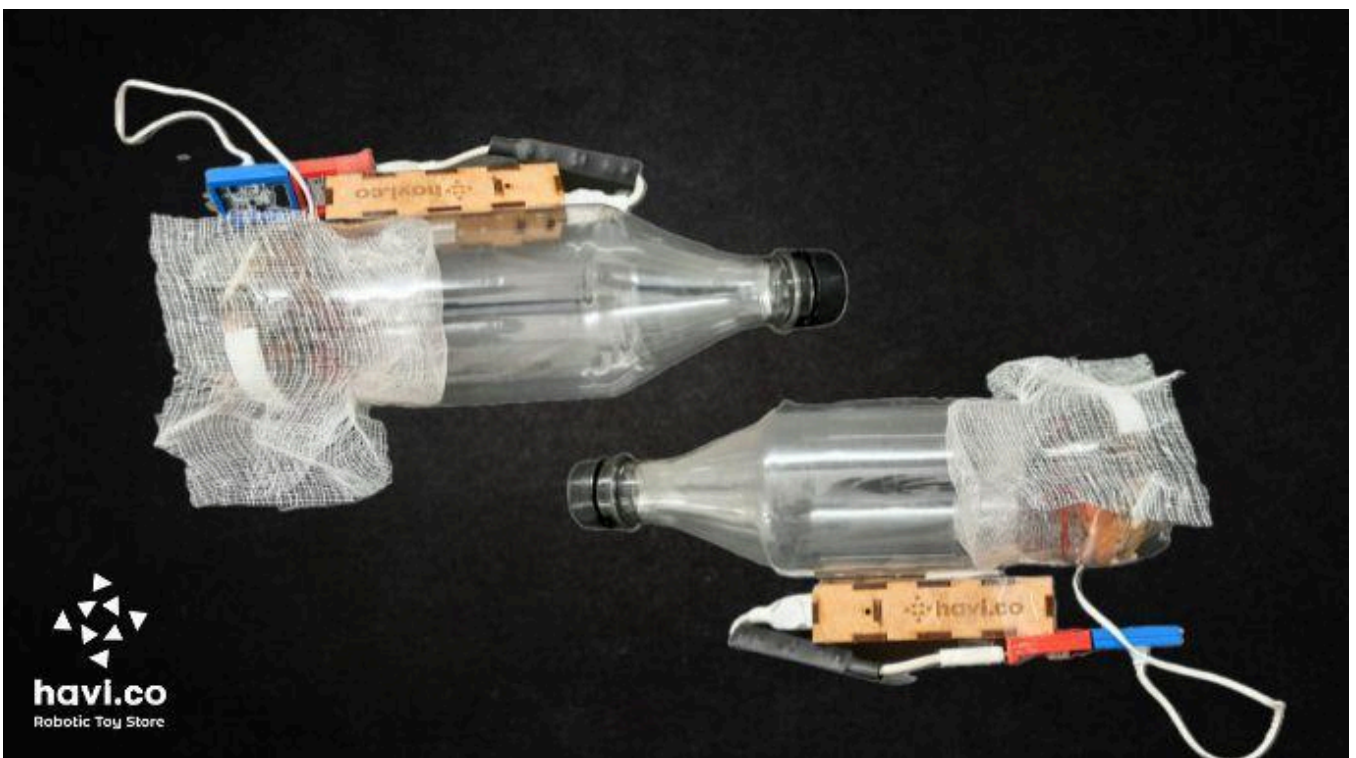
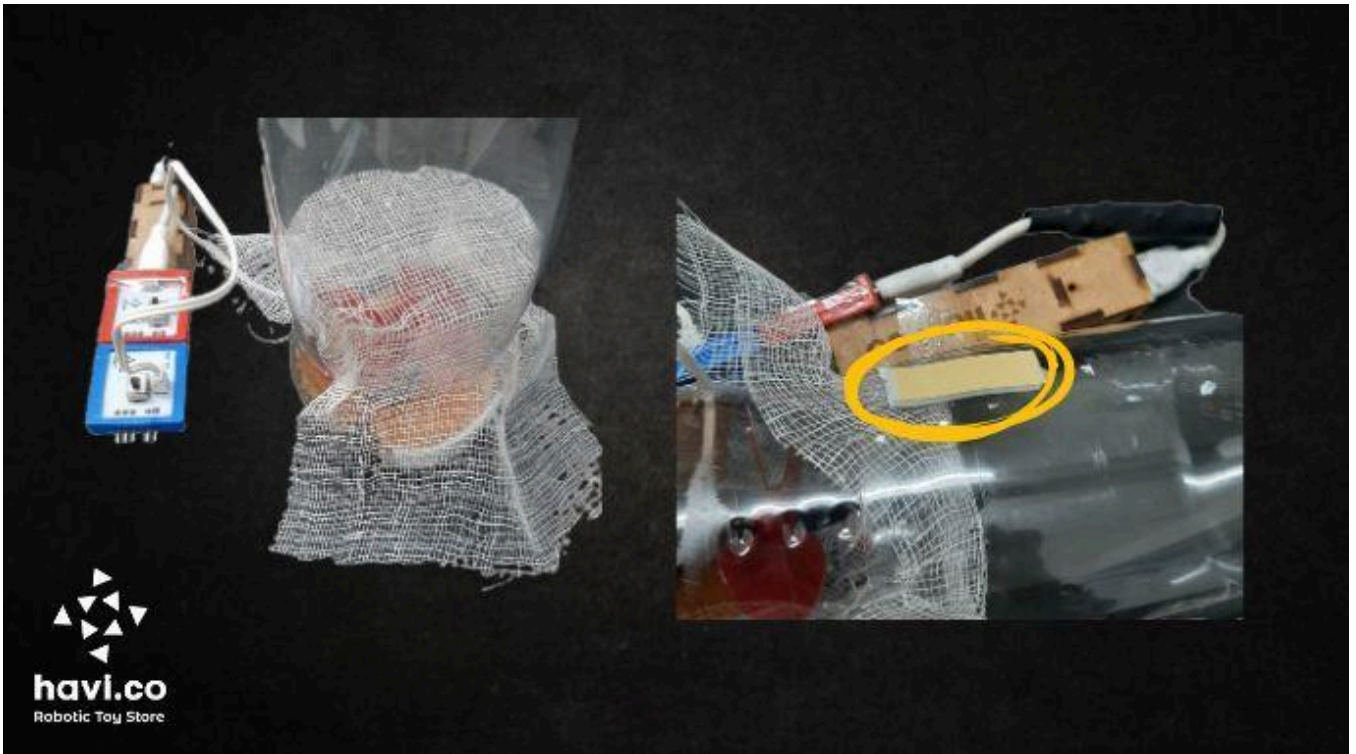

Put some small pieces of paper and keep the opener of the bottle near to it, turn on the circuit and see how your home made vacuum cleaner collects the waste.



### How does it work?

The DIY vacuum cleaner project works on the principle of air suction. When we turn ON the circuit, the current flows from power to the motor element and the connected gearless motor starts to rotate. With the gearless motor, the connected propeller spins and creates a suction. The holes at the bottom of the bottle allows the air to pass by and makes the suction enough capable to suck the debris. The bandage works as the collection net. A question before you start making this DIY vacuum cleaner. What will happen if you use an opaque piece of cloth like a silk handkerchief instead of a bandage which has a net?

## Chapter 21

# Reflex action working model

## - Step by step guide

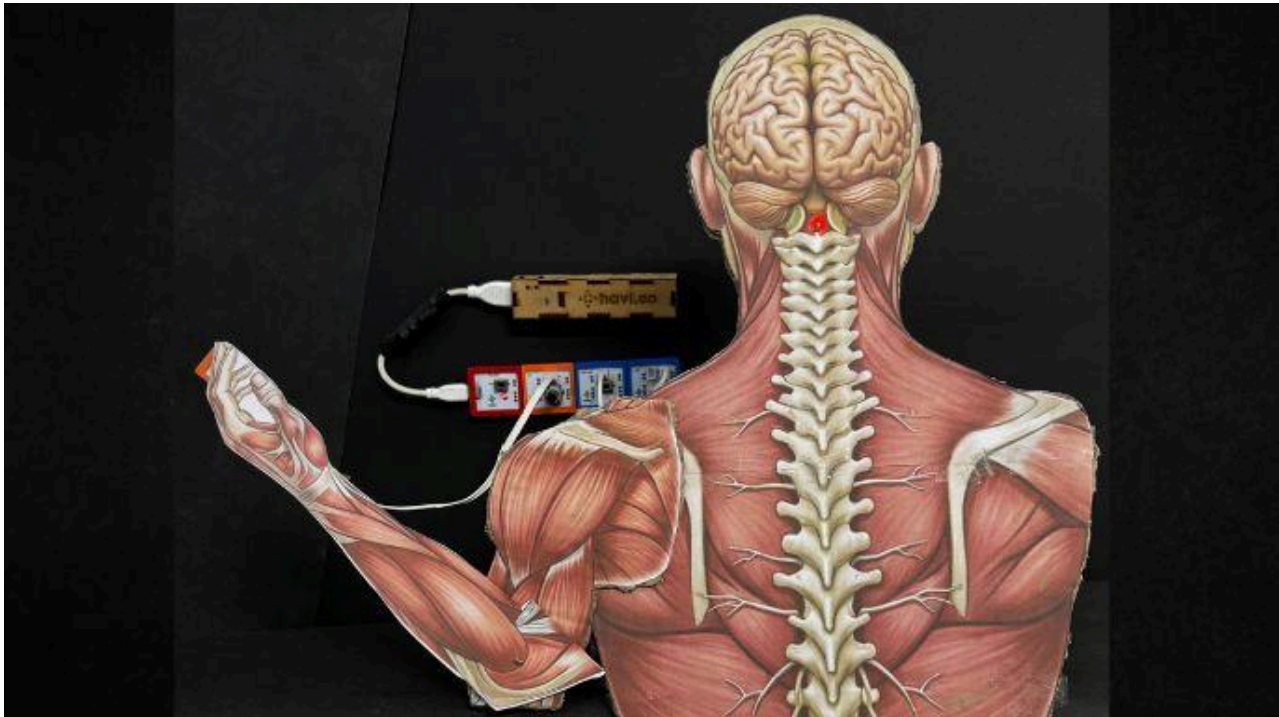

What happens when your hand accidentally touches a hot pan? You pull it back instantly. Ever stepped accidentally on a pointed stone? If Seema pokes a pin on Meena's finger, Meena immediately moves her hand away. This quick, automatic response — happening in a matter of milliseconds — is called reflex action.

What is reflex action?

Reflex action is an immediate, involuntary and unconscious response of the body to a sudden stimulus. It happens without the involvement of the brain because the reaction must be extremely fast. Instead, the spinal cord handles the processing to protect the body from harm.

Reflex arc pathway

Let's understand the reflex arc with a simple example:

- When you touch a hot object, your skin acts as the receptor and senses the danger.
- Sensory neurons carry this signal to the spinal cord.
- The relay neuron inside the spinal cord processes the information.
- A quick response is generated and sent through motor neurons.
- The signal reaches your muscles, causing you to instantly take your hand away.

Is the brain involved in reflex action?

Not directly. As the reflected action has to be immediate, all the processing happens in the spinal cord. Later on, the spinal cord informs the brain about whatever happened in the body so that the brain can learn and further actions can be taken.

That's all about the biology behind the reflex action. Now, let's understand reflex action by making a working model. You can make this model by using Havi robotics kits, Craft materials and free downloadable-printable templates.

## Things you need

Elements	Accessories	Craft material
Power Motor IR LED	Geared motor LED Cable Power bank with USB Cable 3-pin cable	Project templates Card board Card paper Glue gun Fevicol Cellotape Double-sided tape Cutter/scissor Wheel grip Skewer stick

## The making

**Step 1** — Download the project templates and take a printout on three A4 sheets. Color prints are recommended.

**Step 2** — Cut the body-part templates from the printouts. Take the parts containing the spinal cord and head, align the nerve lines, overlap them, and join them using tape to form a human body shape.

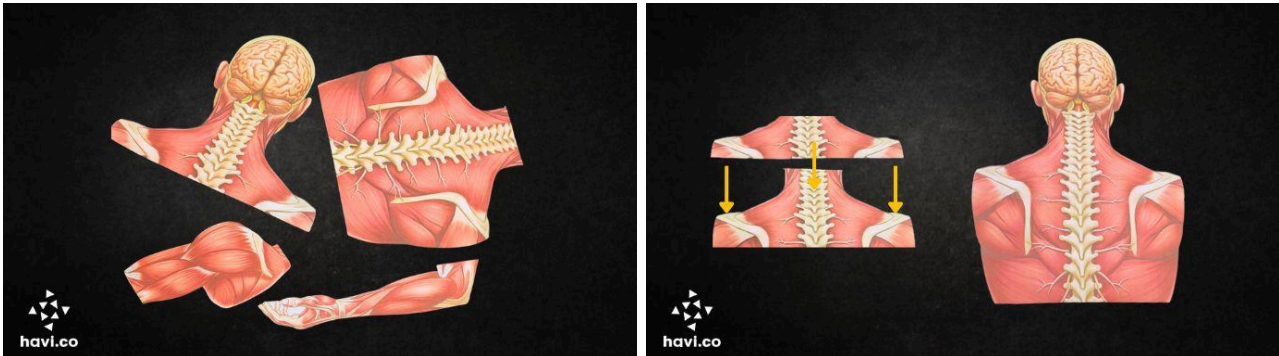

**Step 3** — Place the human body template over cardboard. Trace the outline using a pencil, cut the cardboard using a cutter, and paste the paper template on it.



**Step 4** — You now have two hand templates — one showing muscles and the other showing fingers. Repeat Step 3 for both, but use cardboard for the muscle part and card paper for the fingers part.

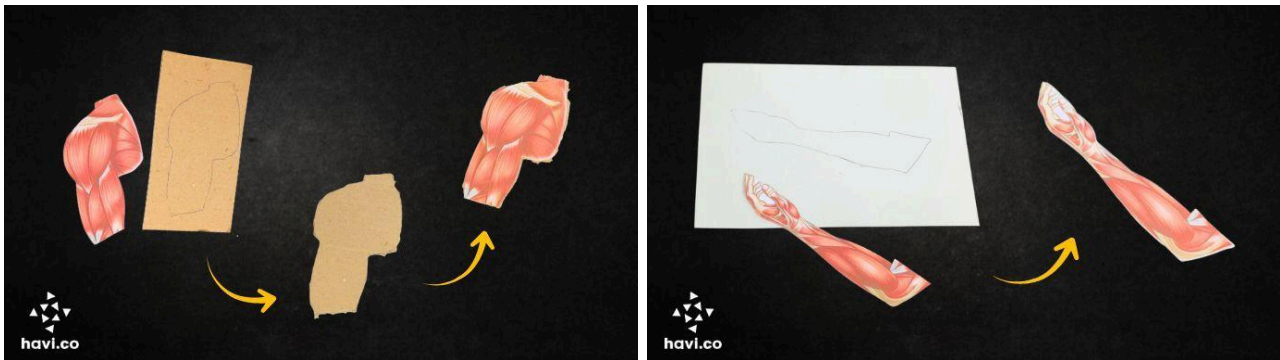

**Step 5** — Attach the muscle hand part onto the main body. Make a small hole at the bottom of the hand muscle and fix the geared motor behind the cardboard using a glue gun. Ensure the motor shaft faces outward. Adult supervision is recommended for young kids while using glue-gun.

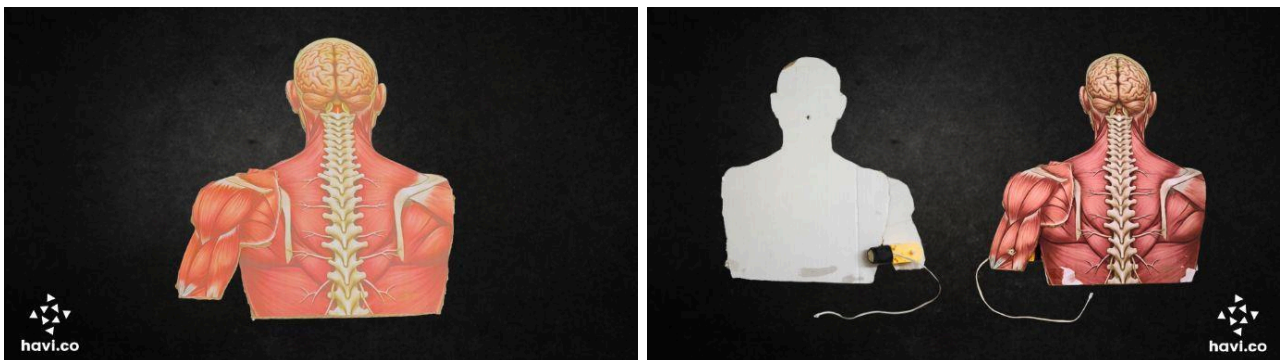

**Step 6** — Make a hole at the corner of the moving hand part (fingers). Stick a skewer to the back for balance. Attach the wheel grip to the skewer using a glue gun. Ensure the wheel grip hole is aligned with the hand hole. Now fix the wheel grip to the motor shaft.

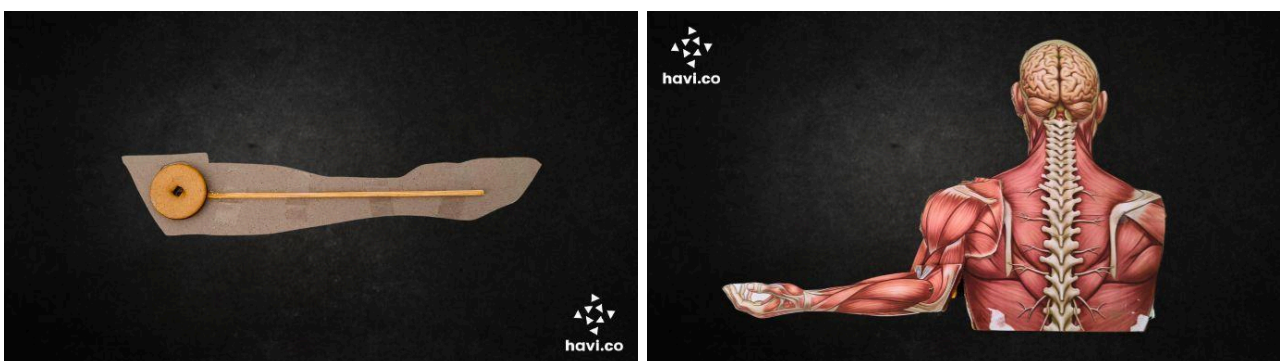

**Step 7** — Snap the circuit: Power + IR + Motor + LED. Connect both the IRs using a 3-pin cable. Connect LED Cable with the LED Element.

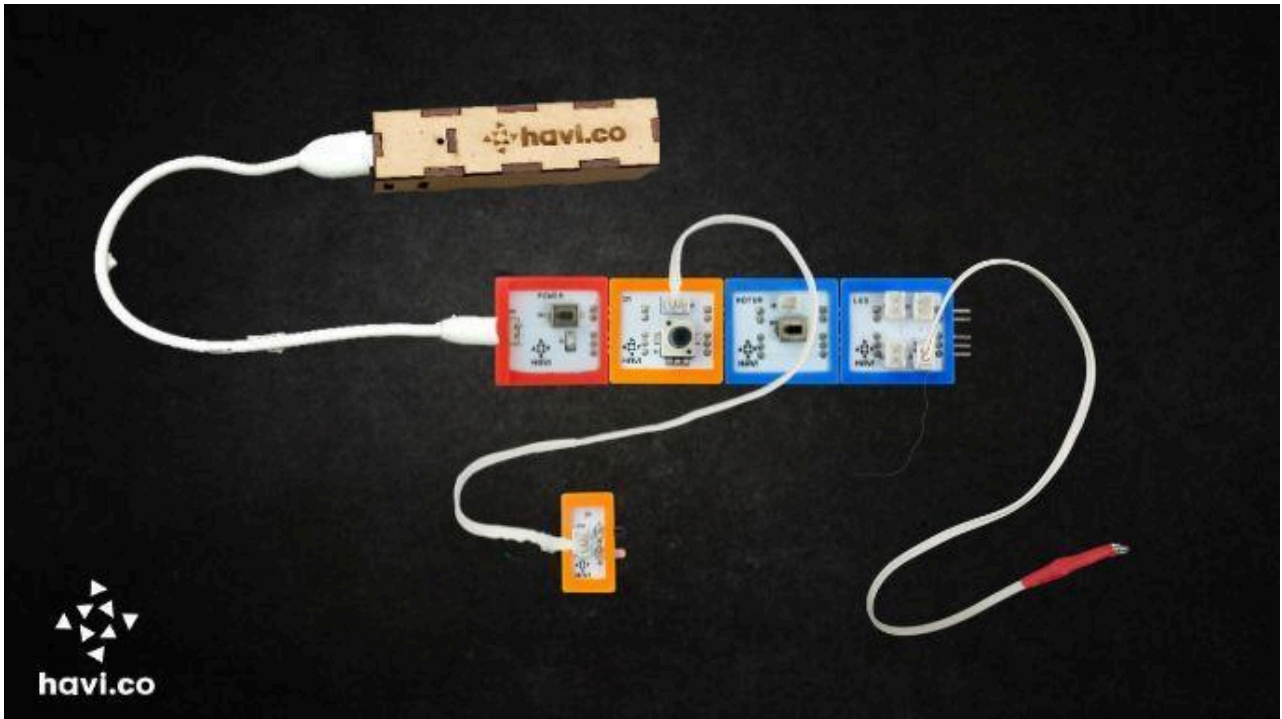

**Step 8** — Stick the small IR at the edge of the hand as shown in the image. Make a hole near the spinal cord area of the template and pass the LED cable through it. The model is almost ready.

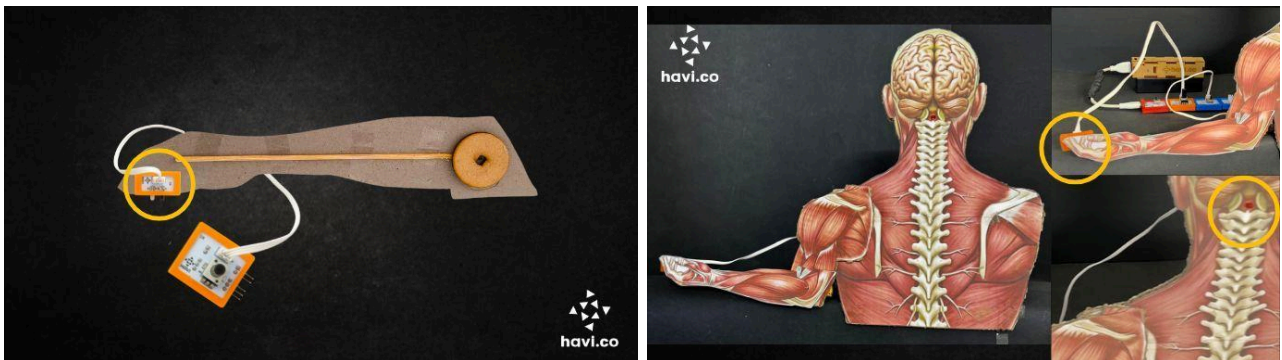

**Step 9** — Connect the geared motor with the Motor Element. Keep the setup ready as shown in the image. Your reflex action working model is ready now.

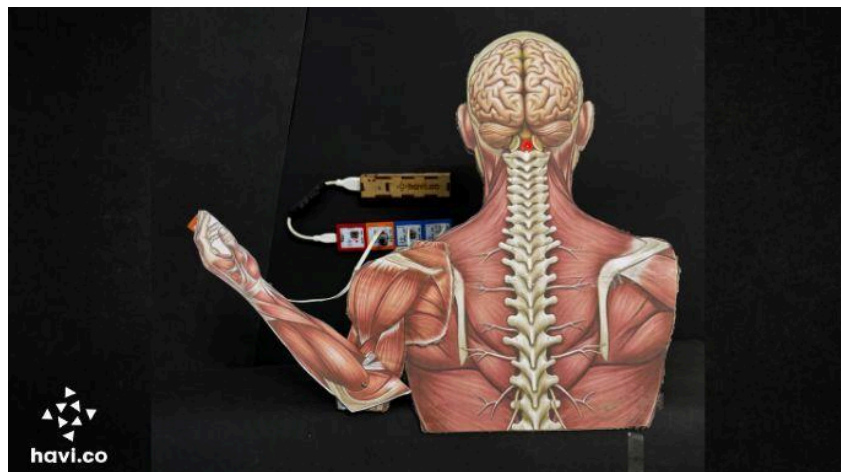

## How does it work?

Using the Havi robotics kit and the printable template, this model demonstrates how reflex action happens inside the human body. •

- The IR sensor acts as the sensory receptor, detecting fire flame here.
- The signal flows from Power → IR → Motor → LED Element, just like impulses flow in neurons.
- When the IR detects a stimulus, it sends a YES signal forward.
- The Motor Element, representing the motor neuron, activates the geared motor.
- This rotates the attached hand template, showing how your real hand instantly pulls away.
- The LED Element represents the immediate response inside the spinal cord. As soon as the LED receives YES, it glows, showing that processing happens in the spinal cord first. Thus, just like in our body, the model shows an immediate action without involving the brain initially — perfectly demonstrating a reflex action.

Isn't this a simple and exciting way to understand reflex action and create a working biology model for science exhibitions? Teachers and parents — the next time you want to explain reflex action to students, use this working model. Students will not only enjoy making it but will also remember the concept for life.

---

*Explore 100+ STEAM & Robotics projects with [Havi's DIY Kits](#).  
Visit [havi.co](http://havi.co) to discover more.*

*For any queries, questions related to any project, or to get the components to make the project, call/WhatsApp on 7041681929 or email on [toys@havi.co](mailto:toys@havi.co)*